

Friday, September 2nd Ranch Trail Pattern

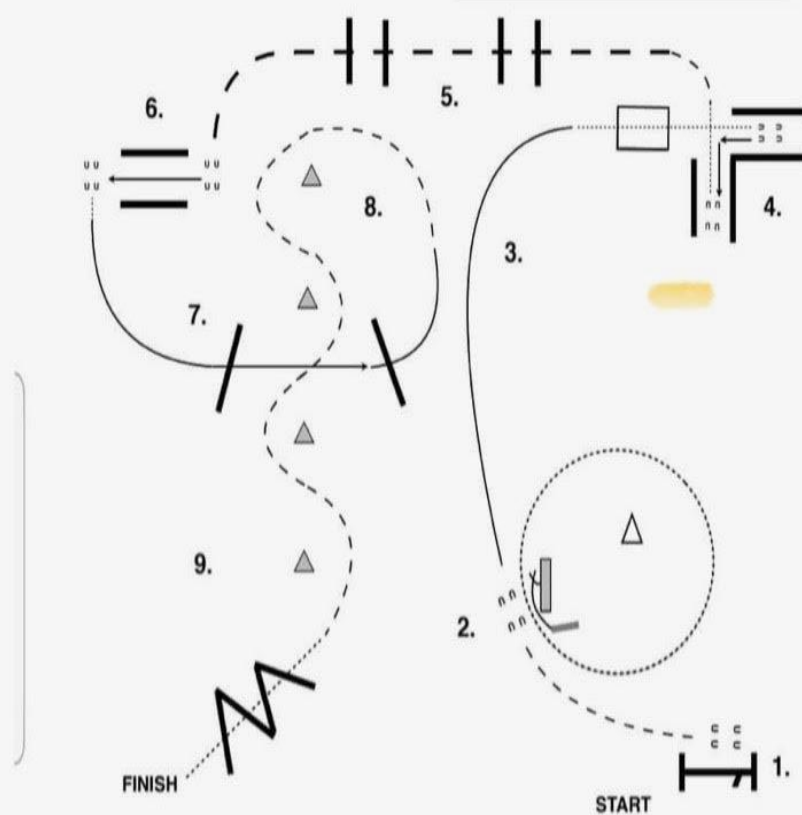

1. WORK GATE LEFT HAND PUSH GATE OPEN AND CLOSE.
2. TROT UP TO DRAG, PICK UP ROPE, DRAG LOG TO THE RIGHT (WALK OR TROT), RETURN ROPE. YOUTH TRAIL WALKS UP AND PICKS UP ROPE, THEN HANGS ROPE BACK.
3. LOPE UP TO BRIDGE RIGHT LEAD, BREAK TO THE WALK, WALK OVER BRIDGE.
4. WALK INTO CHUTE, STOP, BACK AND "L" BETWEEN POLES, WALK OUT CHUTE.
5. FIRST TROT, THEN EXTEND THE TROT OVER LOGS AND CONTINUE UP TO SIDE PASS.
6. STOP AND SIDE PASS RIGHT BETWEEN LOGS.
7. WALK FORWARD, THEN LOPE OVER LOGS LEFT LEAD.
8. BREAK TO THE TROT, TROT THROUGH SERPENTINE.
9. BREAK TO THE WALK, WALK OVER LOGS.



All Ranch Riding

Show Date: Friday, September 2nd

www.HorseShowPatterns.com

www.HorseShowPatterns.com

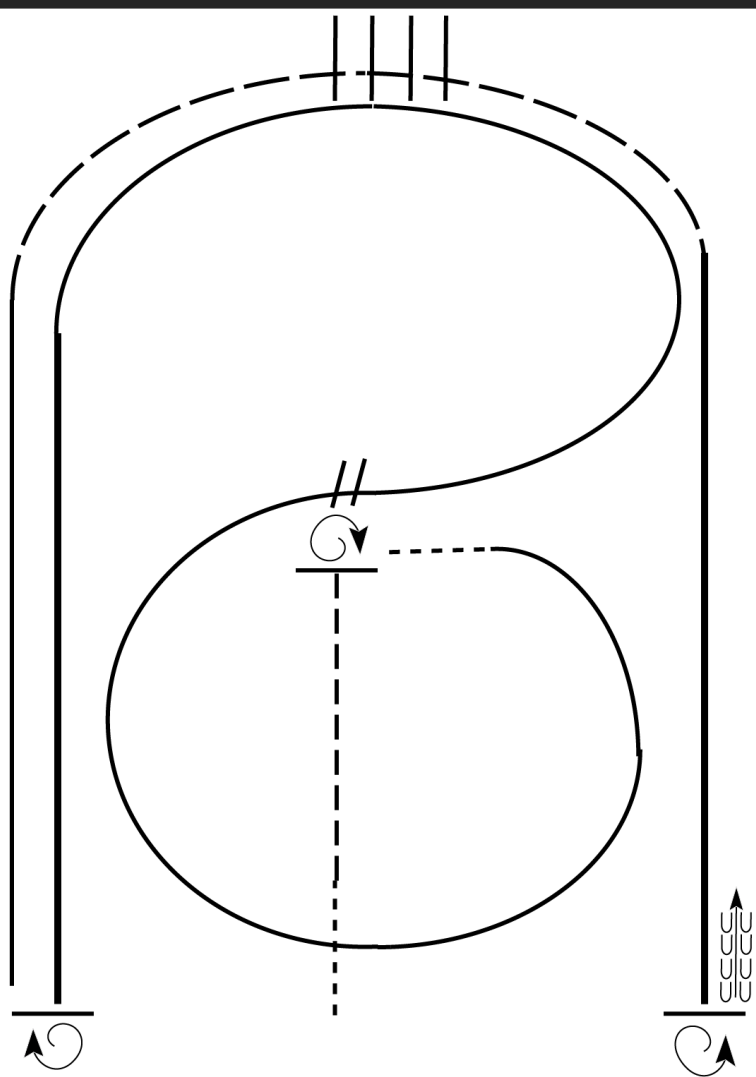

1. Walk
2. Jog
3. Stop, do a 1 1/4 turn to the right
4. Walk. Then, lope small circle on the right lead
5. Change leads, (simple or flying) lope left lead around end of the arena
6. Extend the lope on the left lead
7. Stop, do a 2 1/2 turns right
8. Lope straight on the right lead
9. Extend the jog around end of the arena across poles/logs
10. Extend the lope on right lead
11. Stop, do 2 turns left
12. Back

Walk	-----
Jog	-----
Extended Jog	-----
Lope	-----
Lead Change	////
Back	←-----
Marker	(B)

[RR/6]

Pattern Provided by:

Judges

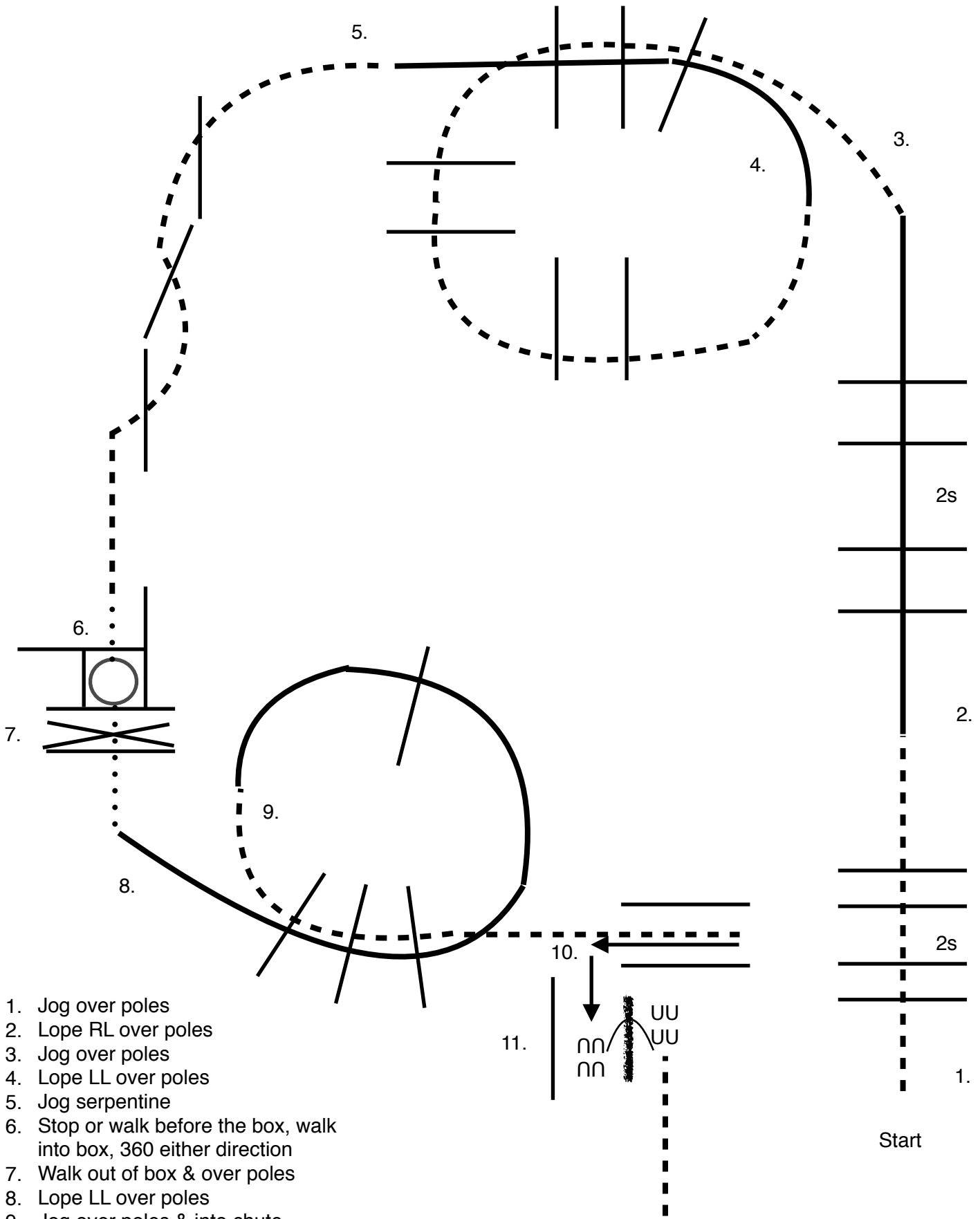

1. Jog over poles
2. Lope RL over poles
3. Jog over poles
4. Lope LL over poles
5. Jog serpentine
6. Stop or walk before the box, walk into box, 360 either direction
7. Walk out of box & over poles
8. Lope LL over poles
9. Jog over poles & into chute
10. Back L to the gate
11. Perform RH gate & jog out

Start

Walk Trot

* small fry can skip gate

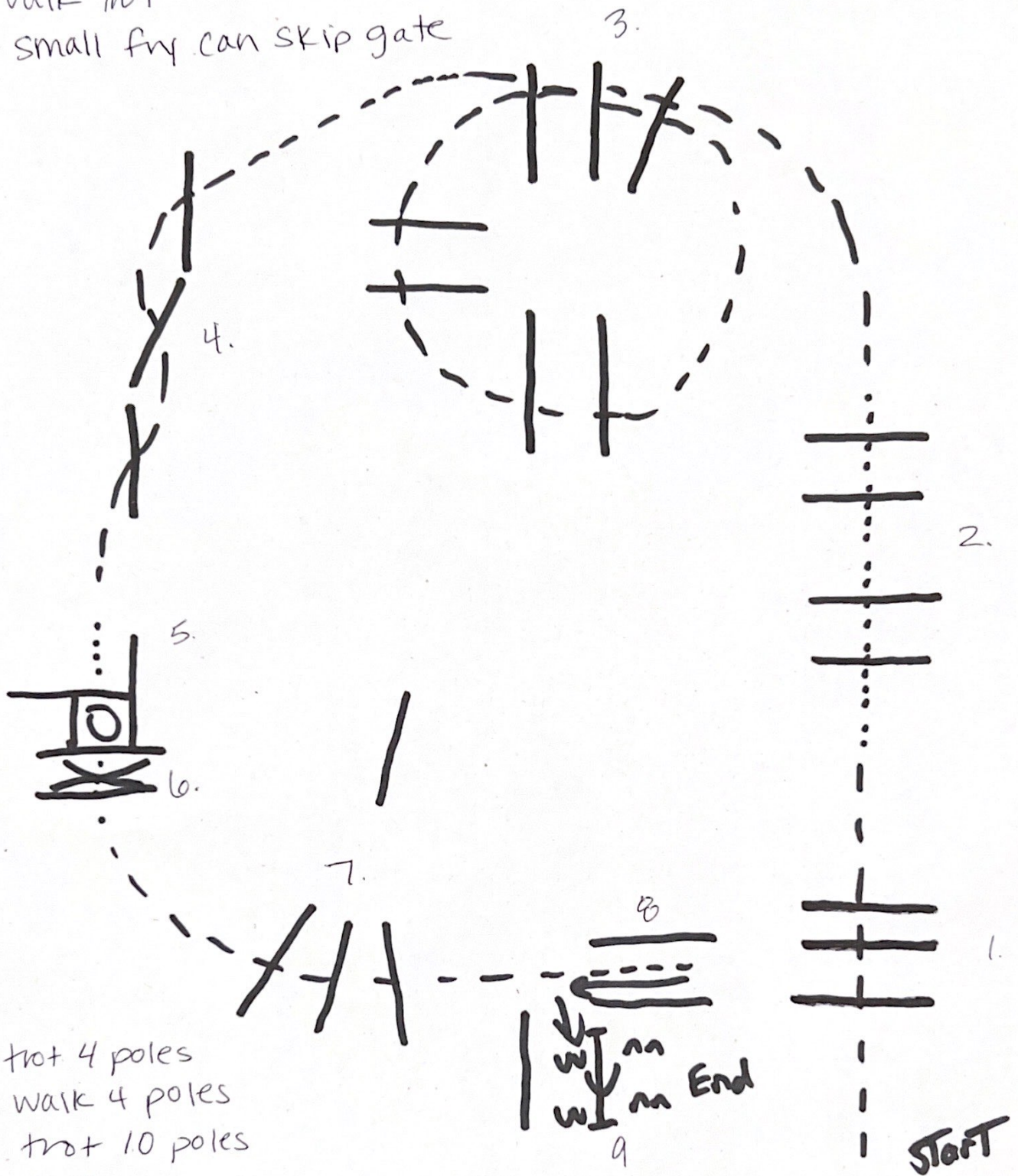

1. trot 4 poles
2. walk 4 poles
3. trot 10 poles
4. trot serpentine
5. stop ~~and~~ or walk, walk into box, turn either direction
6. walk out of box + over poles
7. trot 3 poles + into chute
8. back L
9. work right hand gate

Friday, September 2nd

Western Riding Pattern

Green Pattern 9

All Other Patterns 9

Nebraska Quarter Horse Labor Day

Showmanship (Small Fry)

Show Date: Friday September 2nd

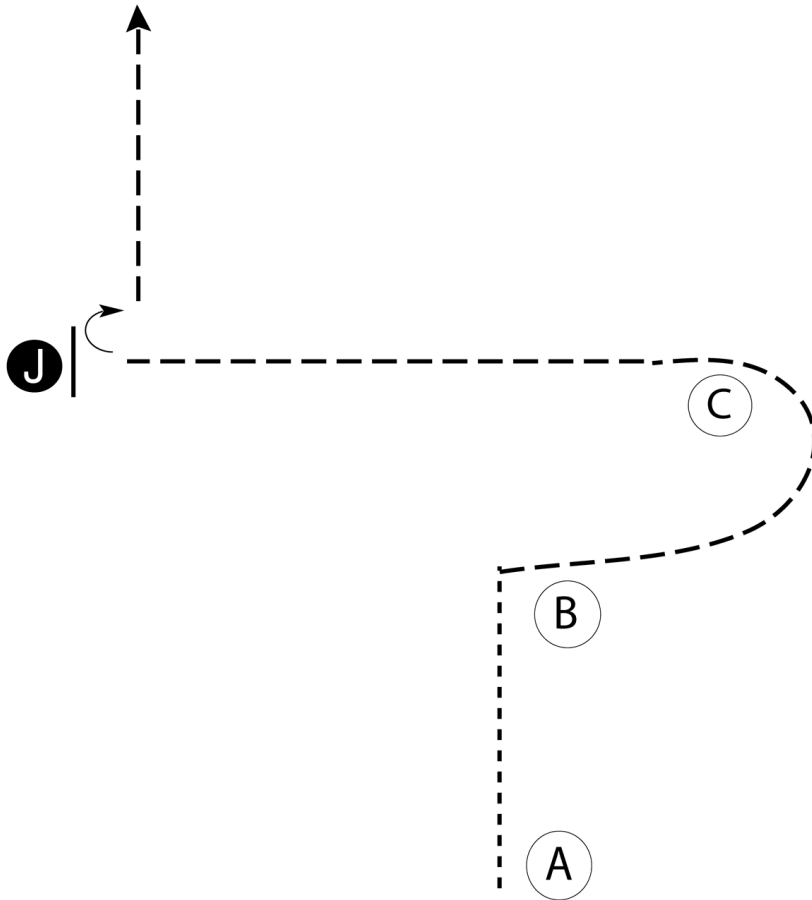

Be ready at A.

1. Walk to B.
2. Trot from B and around C as shown.
3. Continue to trot to judge and set up for inspection.
4. When dismissed, do a 90 degree turn and trot away.

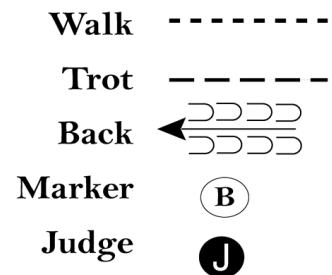

[S/WT-21]

Pattern Provided by:

Libby Michaud

1. Open Left Hand Gate
2. Back the "L"
3. Walk forward and Lope Left lead
4. Trot
5. Lope Right Lead
6. Trot
7. Lope Right Lead
8. Trot
9. Stop or Walk into box 360 turn either way
10. Walk out

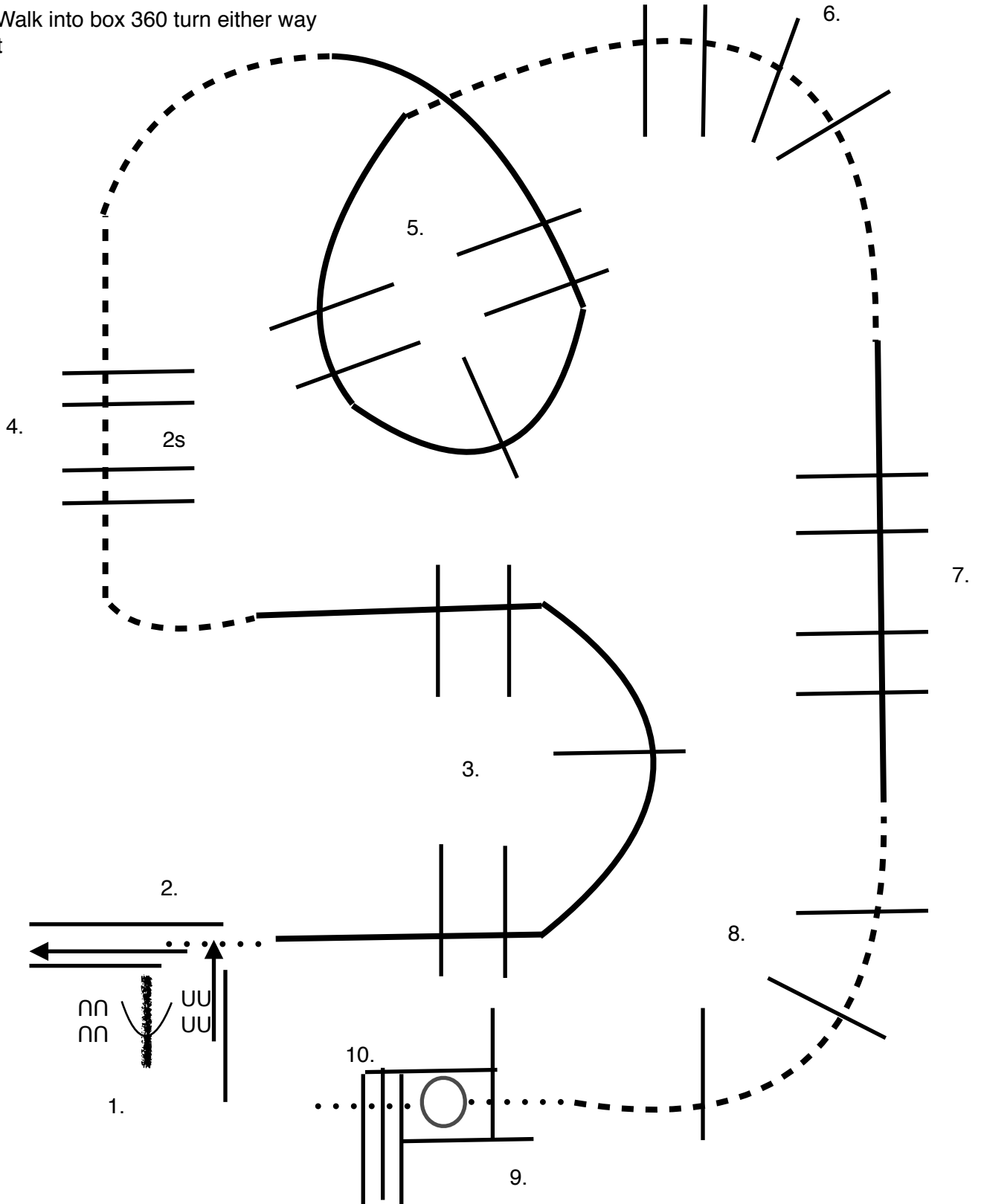

WALK TROT

* Small Fry can skip gate

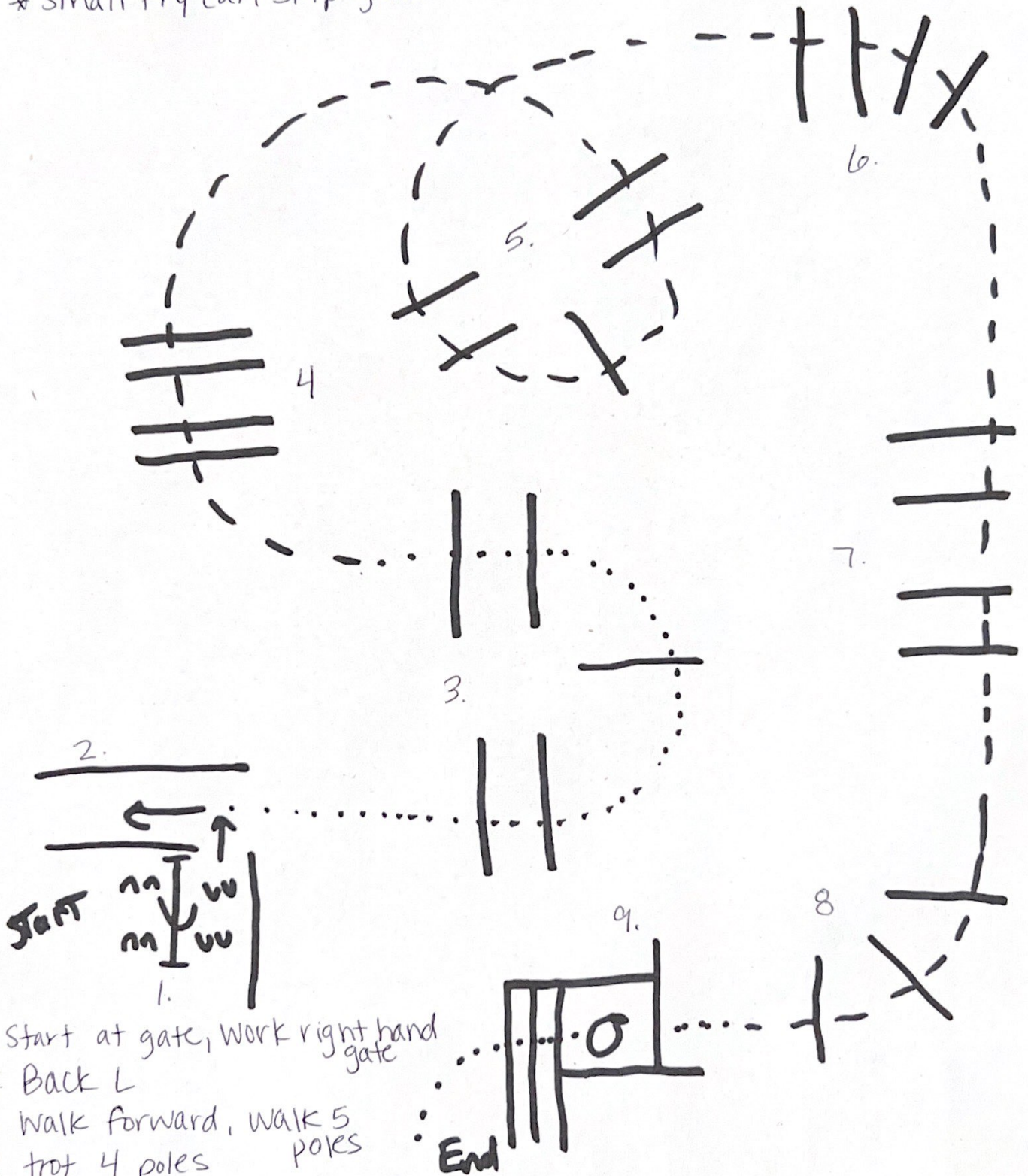

1. Start at gate, work right hand gate
2. Back L
3. Walk forward, WALK 5 POLES
4. trot 4 poles
5. trot 5 poles
6. trot 4 poles
7. trot 4 poles
8. trot 3 poles
9. Stop or walk + walk into box, turn either direction
10. Walk out of box + over poles

Nebraska Quarter Horse Labor Day

Showmanship (All Level 1)

Show Date: Friday September 2nd

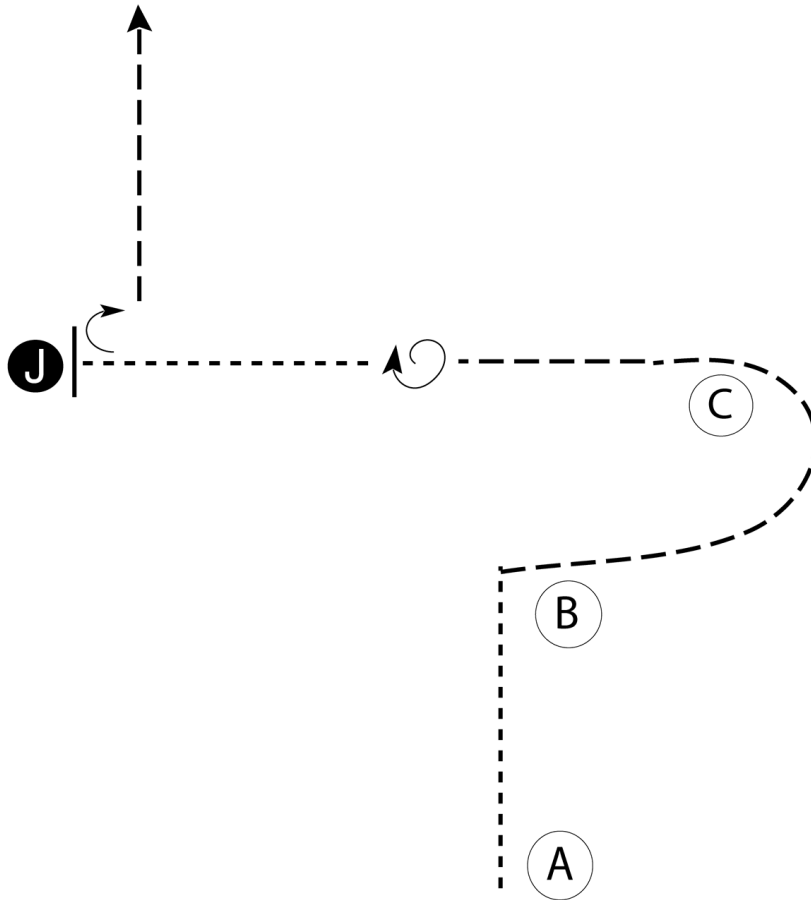

Be ready at A.

1. Walk to B.
2. Trot from B and around C as shown.
3. Halfway between C and the judge, stop and do a 360 degree turn.
4. Walk to judge and set up for inspection.
5. When dismissed, do a 90 degree turn and trot away.

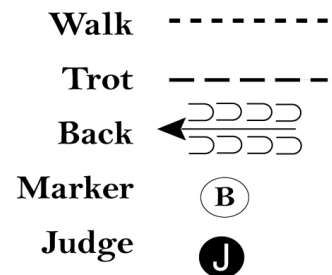

[S/2-21]

Pattern Provided by:

Libby Michaud

w w w . H o r s e S h o w P a t t e r n s . c o m

w w w . H o r s e S h o w P a t t e r n s . c o m

Nebraska Quarter Horse Labor Day Showmanship (Youth, Amateur and Select)

Show Date: Friday September 2nd

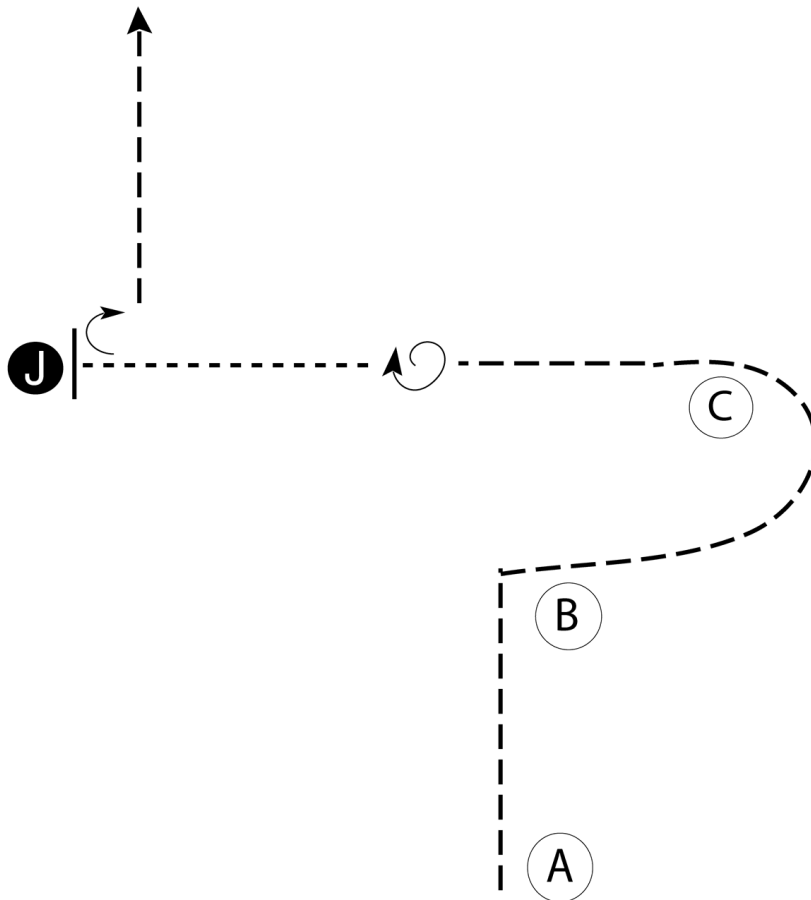

Be ready at A.

1. Trot around B and C as shown.
2. Halfway between C and the judge, stop and do a 360 degree turn.
3. Walk to judge and set up for inspection.
4. When dismissed, do a 90 degree turn and trot away.

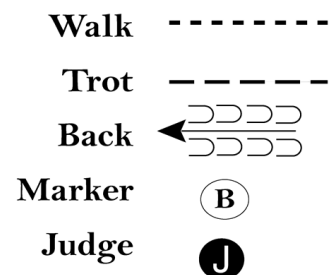

[S/3-21]

Pattern Provided by:
Libby Michaud

Hunt Seat Equitation (Level1)

Show Date: Saturday, September 3rd

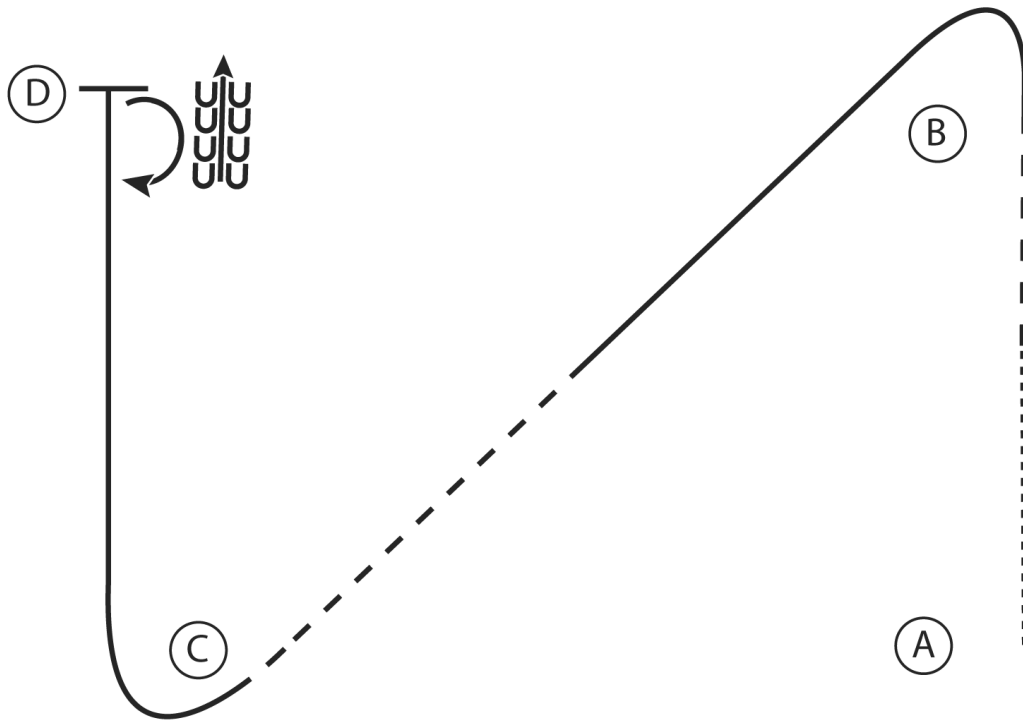

1. Walk halfway from A to B
2. Sitting trot to B
3. At B canter on the left lead halfway to C
4. Posting trot to C
5. At C canter on the right lead to D
6. Stop at D and perform a 180 degree turn to the right on the forehand
7. Back 4 steps

Walk
Trot	-----
Extended Trot	-----
Canter	—————
Leg Yield	
Lead Change	↘
Back	←←←←
Marker	(B)
Sidepass	←←←←

[HSE/2-11]

Pattern Provided by:

Judges

w w w . H o r s e S h o w P a t t e r n s . c o m

w w w . H o r s e S h o w P a t t e r n s . c o m

Hunt Seat Equitation (All Youth)

Show Date: Saturday, September 3rd

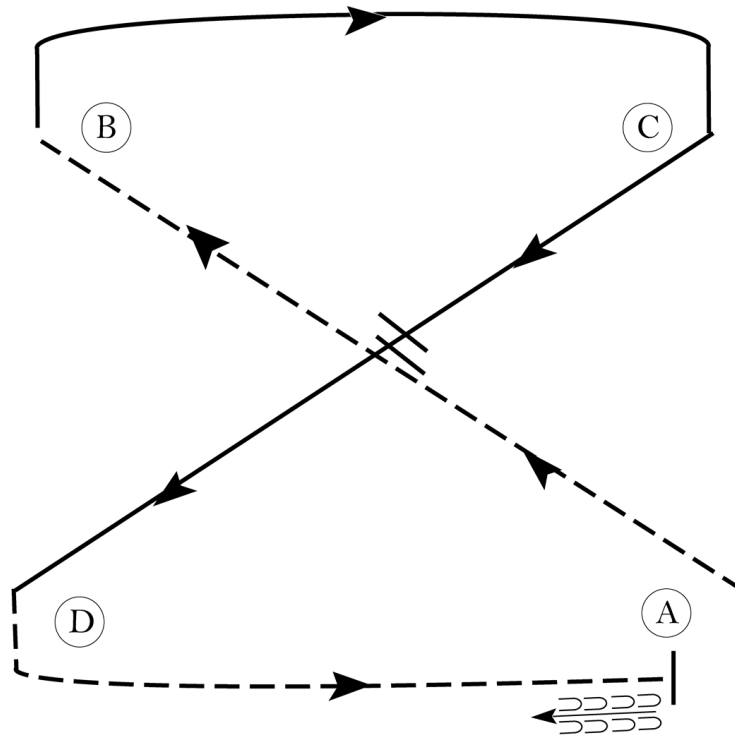

Be ready at A.

1. Posting trot on the left diagonal to B.
2. Canter on the right lead to and around C and 1/2 way to D.
3. Change leads and canter to D.
4. Posting trot on the right diagonal to A.
5. Halt at A and back approximately one horse length.

Exit at a sitting trot.

Walk	-----
Trot	- - - - -
Extended Trot	— — — —
Canter	—————
Leg Yield	
Lead Change	///
Back	←←← ←←←
Marker	Ⓚ
Sidepass	← - - - ←
Hand Gallop	— — — —

[HSE/2-24]

Pattern Provided by:

Judges

Hunt Seat Equitation (All Amateur)

Show Date: Saturday, September 3rd

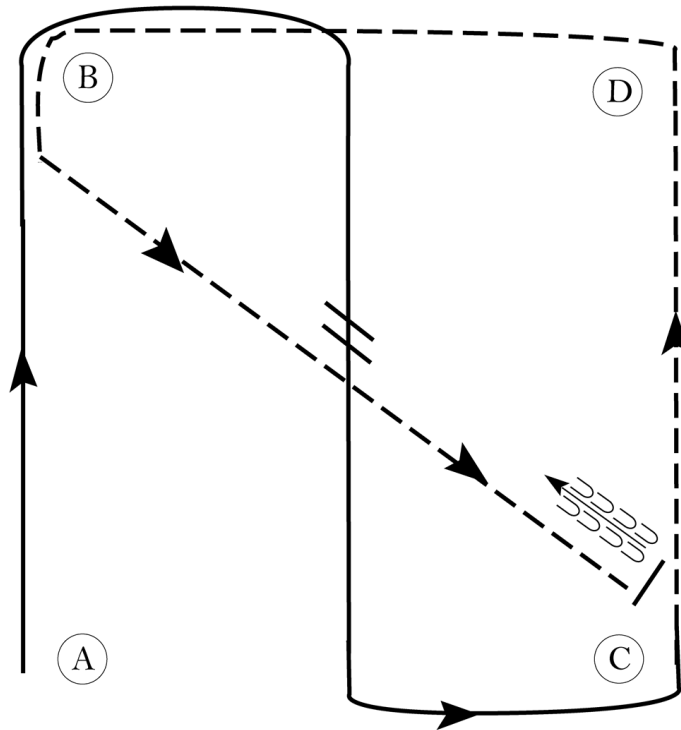

Be ready at A.

1. Canter on the right lead to and around B.
2. Halfway between B and C, change leads.
3. Canter on left lead to and around C.
4. Posting trot on the left diagonal from C to D.
5. At D, change diagonals and continue to trot to B.
6. At B, sitting trot to C.
7. Stop and back one horse length at C.

Walk	-----
Trot	-----
Extended Trot	-----
Canter	-----
Leg Yield	
Lead Change	///
Back	←←←
Marker	Ⓚ
Sidepass	←---←
Hand Gallop	-----

[HSE/2-25]

Pattern Provided by:

Judges

www.HorseShowPatterns.com

www.HorseShowPatterns.com

Western Horsemanship Level 1 All

Show Date: Saturday, September 3rd

w w w . H o r s e S h o w P a t t e r n s . c o m

w w w . H o r s e S h o w P a t t e r n s . c o m

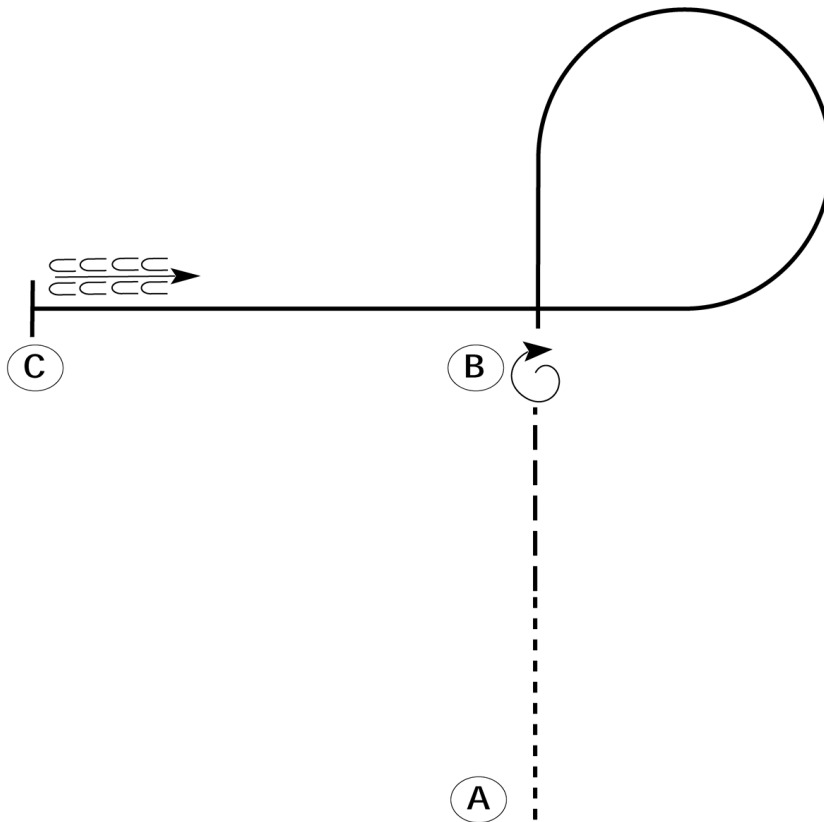

Be ready at A.

1. Walk from A 1/2 way to B.
2. Jog the rest of the way to B.
3. Stop at B and turn 360 degrees to the right.
4. Lope a circle to the right with speed.
5. Slow to a lope at B and continue to C.
6. Stop at C and back one horse length.

Retire to the rail or line up at a jog.

Walk -----

Jog - - - - -

Extended Jog - - - - -

Lope _____

Leg Yield |||||||

Lead Change

Back

Marker (B)

Sidepass

[WH/3-25]

Pattern Provided by:

Judges

Western Horsemanship (All Youth)

Show Date: Saturday, September 3rd

www.HorseShowPatterns.com

www.HorseShowPatterns.com

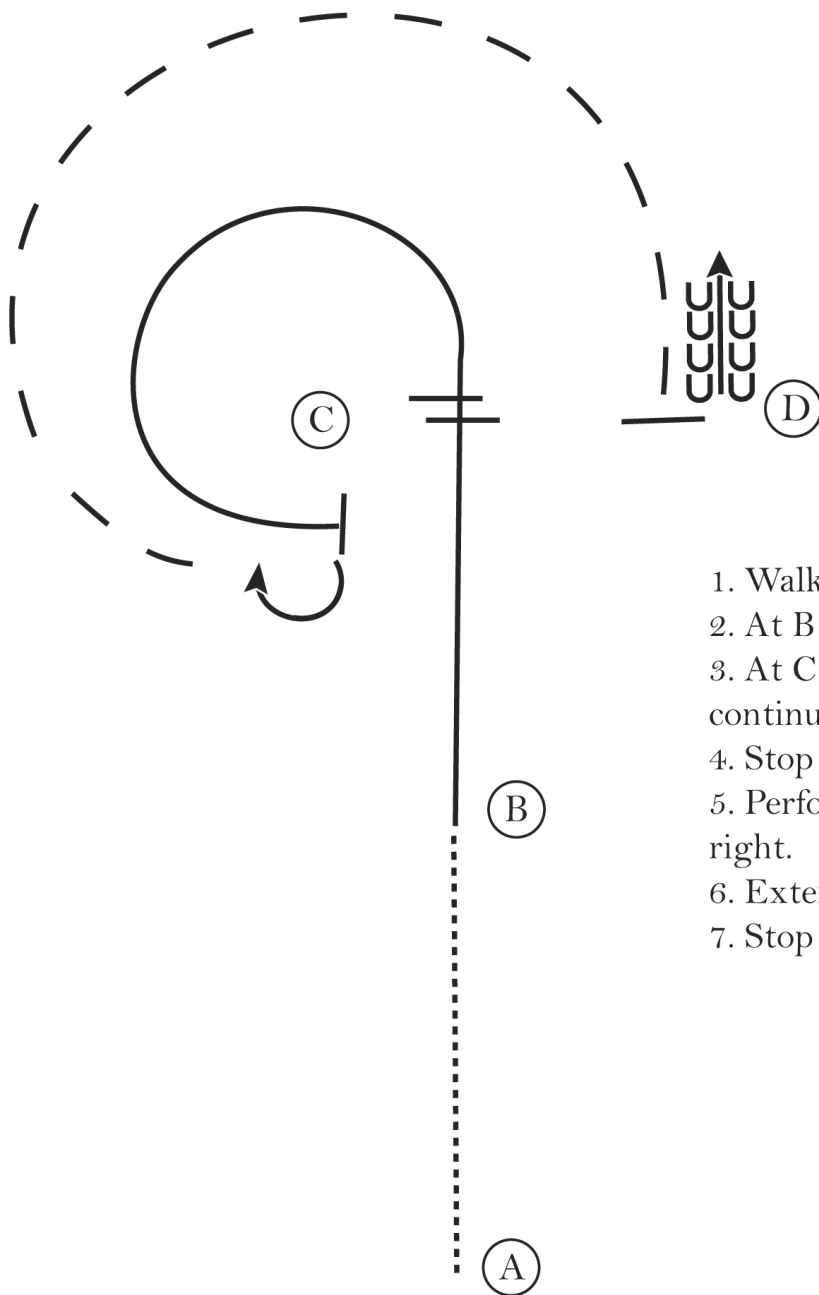

1. Walk A to B.
2. At B lope on the right lead to C.
3. At C perform a lead change and continue on the left lead around C.
4. Stop at C.
5. Perform a 180 degree turn to the right.
6. Extend the jog around C.
7. Stop at D and back 4 steps.

Walk
Jog	-----
Extended Jog	-----
Lope	—————
Leg Yield	
Lead Change	↘
Back	←←←←
Marker	⊙
Sidepass	←←←←

[WH/2-1]

Pattern Provided by:

Judges

Western Horsemanship (All Amateur)

Show Date: Saturday, September 3rd

w w w . H o r s e S h o w P a t t e r n s . c o m

w w w . H o r s e S h o w P a t t e r n s . c o m

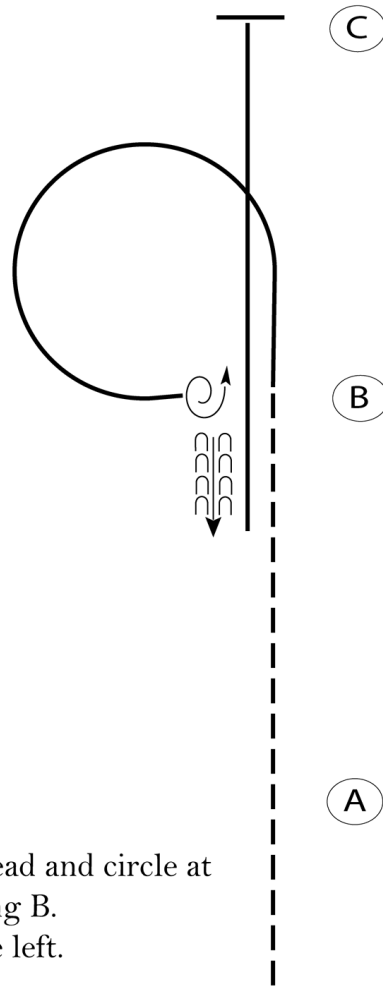

Begin before A at a jog.

1. Jog from A to B.
2. At B, lope on the left lead and circle at B as shown. Stop facing B.
3. Turn 1 1/4 turn to the left.
4. Back one horse length.
5. Lope on the right lead to C. Stop at C.

Follow the instructions of your ring steward.

Walk	-----
Jog	-----
Extended Jog	-----
Lope	—————
Leg Yield	
Lead Change	—/—
Back	← c c c c c
Marker	Ⓚ
Sidepass	←-----→

[WH/2-17]

Pattern Provided by:

Judges

Western Horsemanship (Walk/Trot)

Show Date: Saturday, September 3rd

w w w . H o r s e S h o w P a t t e r n s . c o m

w w w . H o r s e S h o w P a t t e r n s . c o m

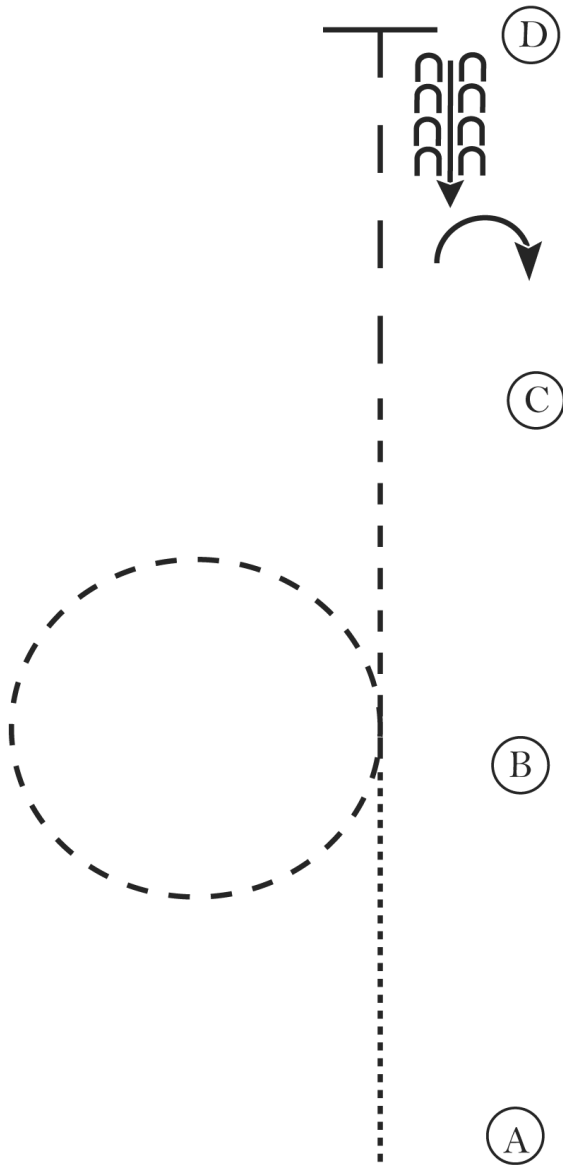

1. Walk A to B.
2. At B jog.
3. Jog a circle at B and continue to C.
4. At C extend the jog to D.
5. At D stop and back 4 steps.
6. Turn 90 degrees to the right.

Walk
Jog	-----
Extended Jog	- - - - -
Lope	—————
Leg Yield	
Lead Change	///
Back	←←←←←
Marker	Ⓚ
Sidepass	←- - - - -→

[WH/WT-11]

Pattern Provided by:

Judges

Level 1

Show Date: Saturday, September 3rd

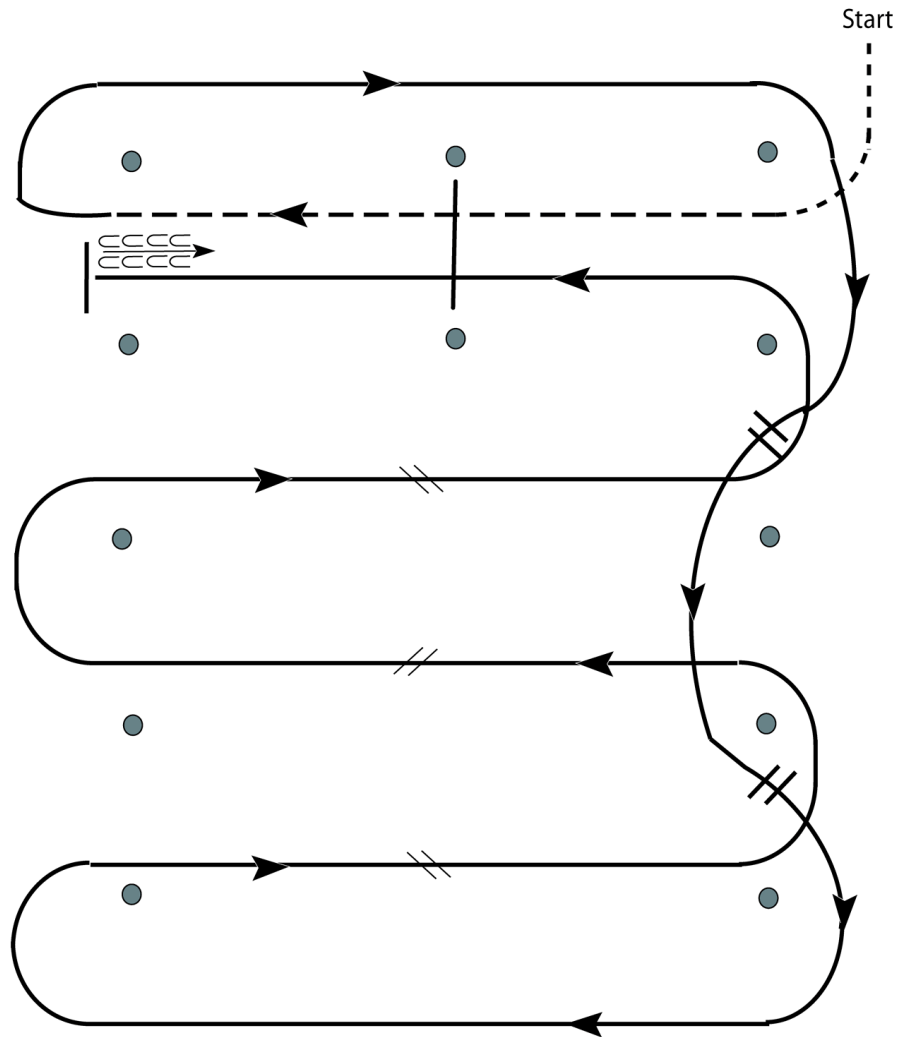

1. Walk, transition to jog, jog over log.
2. Transition to right lead and lope around end.
3. First line change.
4. Second line change. Lope around end of arena.
5. First crossing change.
6. Second crossing change.
7. Third crossing change.
8. Lope over log.
9. Lope, stop and back.

[WR/GP-4]

Pattern Provided by:

Judges

Youth/Amateur/Open

Show Date: Saturday, September 3rd

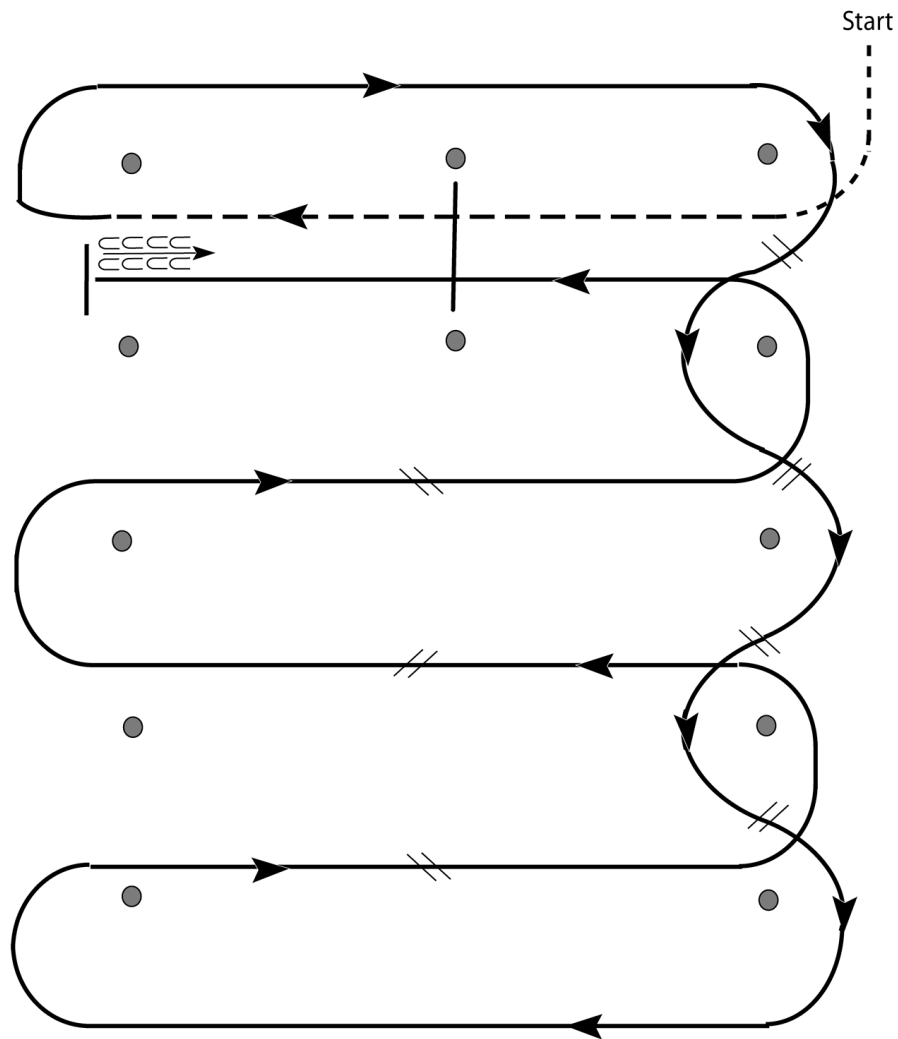

1. Walk, transition to jog, jog over log.
2. Transition to right.
3. First line change.
4. Second line change.
5. Third line change.
6. Fourth line change.
7. First crossing change.
8. Second crossing change.
9. Third crossing change.
10. Lope over log.
11. Lope, stop and back.

[WR/OP-4]

Pattern Provided by:

Judges

Nebraska Quarter Horse Labor Day

Reining (Open, Youth, Amateur and Select)

Show Date: Saturday, September 3rd

REINING PATTERN 7

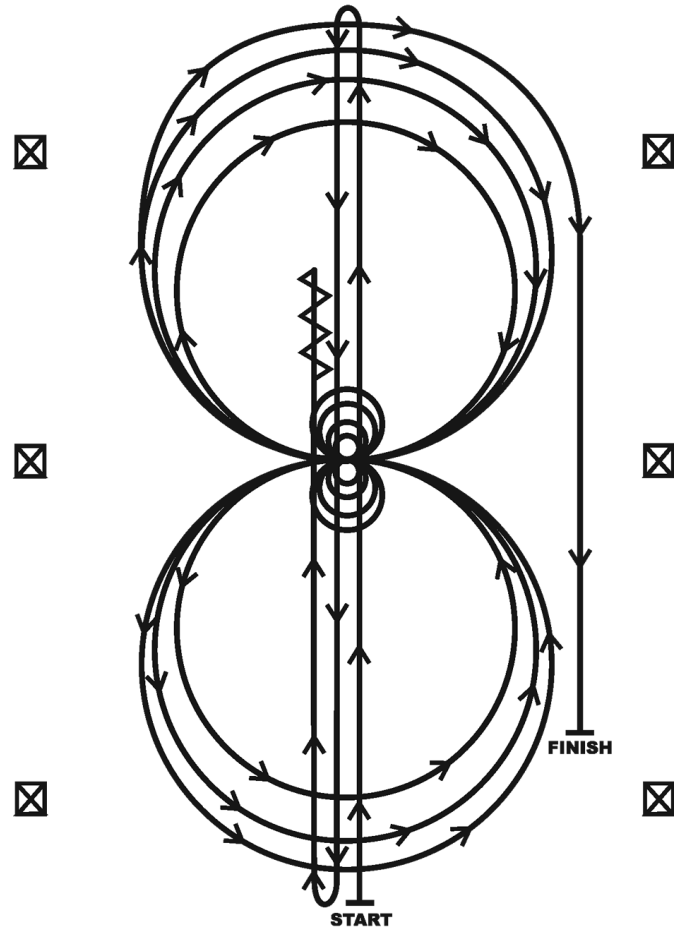

1. Run at speed to the far end of the arena past the end marker and do a left rollback—no hesitation.
2. Run to the opposite end of the arena past the end marker and do a right rollback—no hesitation.
3. Run past the center marker and do a sliding stop. Back up to the center of the arena or at least ten feet (three meters). Hesitate.
4. Complete four spins to the right. Hesitate.
5. Complete four and one-quarter spins to the left so that horse is facing left wall or fence. Hesitate.
6. Beginning on the right lead, complete three circles to the right: the first two circles large fast; the third circle small and slow. Change leads at the center of the arena.
7. Complete three circles to the left: the first two circles large fast; the third circle small and slow. Change leads at the center of the arena.
8. Begin a large circle to the right but do not close this circle. Run straight down the right side of the arena past the center marker and do a sliding stop at least twenty feet (six meters) from the wall or fence. Hesitate to demonstrate completion of the pattern.

[R/AQHAP-7]

Pattern Provided by:

Libby Michaud

Nebraska Quarter Horse Labor Day

Reining (Level 1 Youth and Amateur)

Show Date: Saturday, September 3rd

REINING PATTERN 11

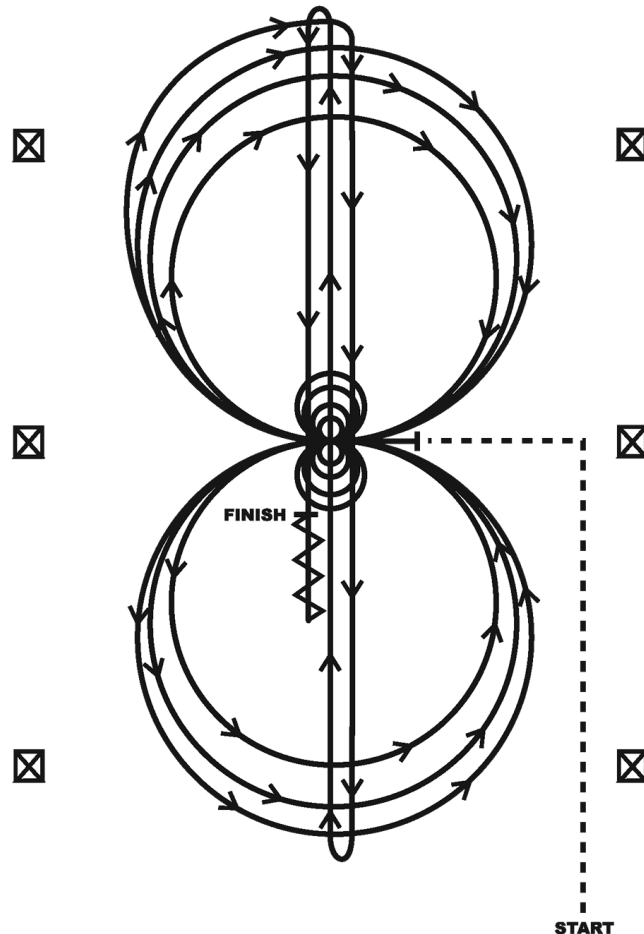

Horses must jog to the center of the arena. Horses must walk or stop prior to starting the pattern. Beginning at the center of the arena facing the left wall or fence.

1. Complete four spins to the left. Hesitate.
2. Complete four spins to the right. Hesitate.
3. Beginning on the right lead complete three circles to the right; the first circle small and slow; the next two circles large and fast. Change leads at the center of the arena.
4. Complete three circles to the left; the first circle small and slow; the next two circles large and fast. Change leads at the center of the arena.
5. Begin a large circle to the right, but do not close this circle. Run down the center of the arena past the end marker and do a right rollback—no hesitation.
6. Run up the middle to the opposite end of the arena past the end marker and do a left rollback—no hesitation.
7. Run past the center marker and do a sliding stop. Back up to the center of the arena or at least ten feet (three meters). Hesitate to demonstrate completion of the pattern.

[R/AQHAP-11]

Pattern Provided by:

Libby Michaud

Nebraska Quarter Horse Labor Day

Ranch Riding (All Classes)

Show Date: Saturday, September 3rd

www.HorseShowPatterns.com

www.HorseShowPatterns.com

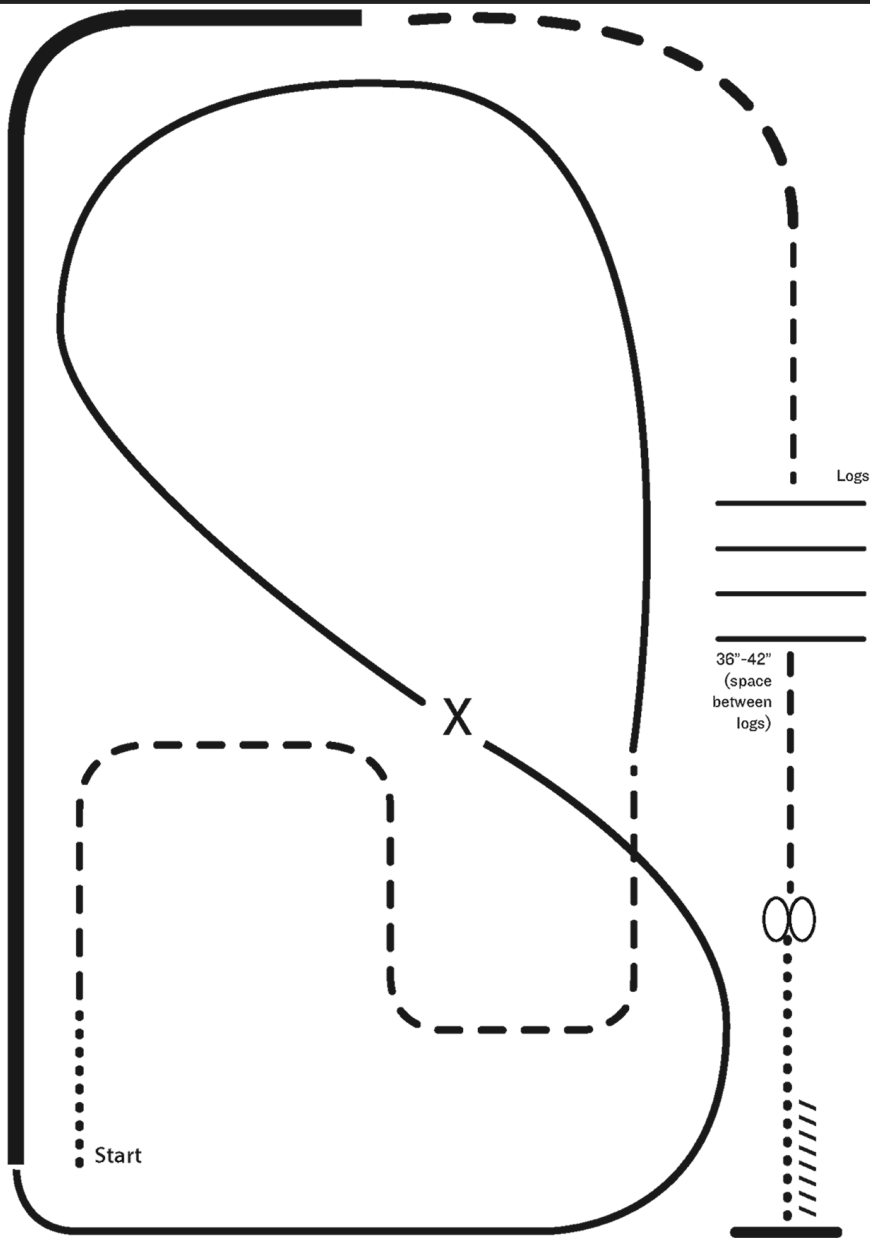

- X Lead Change
- Walk
- - - Trot
- - - Ext trot
- — — Lope
- — — Ext Lope
- ////// Back

1. Walk
2. Trot serpentine
3. Lope left lead around the end of the arena and then diagonally across the arena
4. Change leads (simple or flying) and
5. Lope on the right lead around end of the arena
6. Extend lope on the straight away and around corner to the center of the arena
7. Extend trot around corner of the arena
8. Collect to a trot
9. Trot over logs
10. Stop, do 360 degree turn each direction (either direction 1st) (L-R or R-L)
11. Walk, stop and back

[RR/AQHA-3]

Pattern Provided by:
Libby Michaud

Nebraska Quarter Horse Labor Day

Equitation (Amateur and Youth)

Show Date: Sunday, September 4th, 2022

W W W . H O R S E S H O W P A T T E R N S . C O M

W W W . H O R S E S H O W P A T T E R N S . C O M

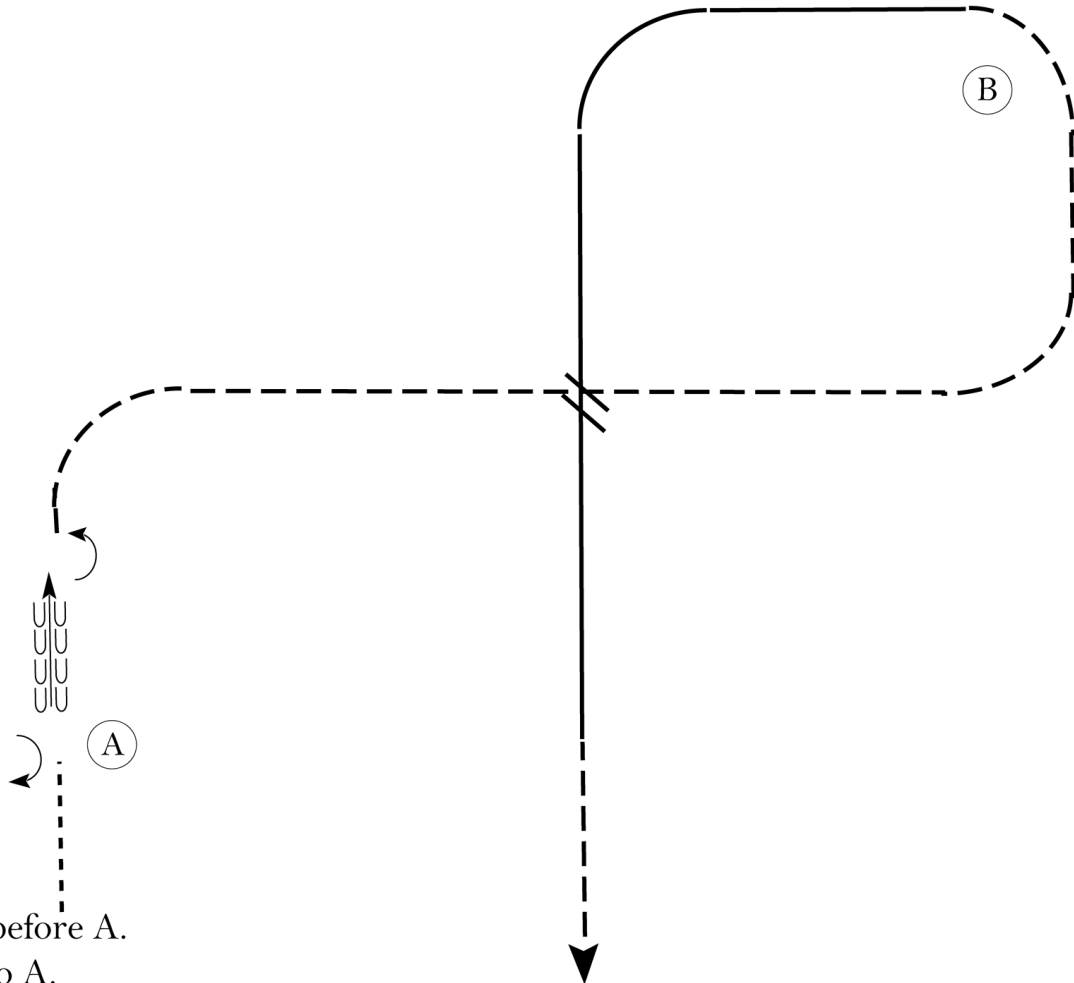

Be ready before A.

1. Walk to A.
2. Perform a 180 degree turn on the forehand right.
3. Back approximately one horse length.
4. Perform a 180 degree turn on the forehand left.
5. Posting trot on the left diagonal to center of pattern.
6. Change diagonals at center. Trot on the right diagonal to B.
7. Canter on the left lead to center of pattern.
8. Change leads at center. Canter on right lead until even with A.
9. Sitting trot when even with A. Pattern is over after trotting 3 strides past A.

Follow the instructions of your ring steward.

Walk	-----
Trot	- - - - -
Extended Trot	-----
Canter	—————
Leg Yield	
Lead Change	↘
Back	←←←←←
Marker	⊙
Sidepass	←-----→
Hand Gallop	-----

[HSE/3-66]

Pattern Provided by:

Libby Michaud

Nebraska Quarter Horse Labor Day

Horsemanship (Select, Amateur and Youth)

Show Date: Sunday, September 4th, 2022

www.HorseShowPatterns.com

www.HorseShowPatterns.com

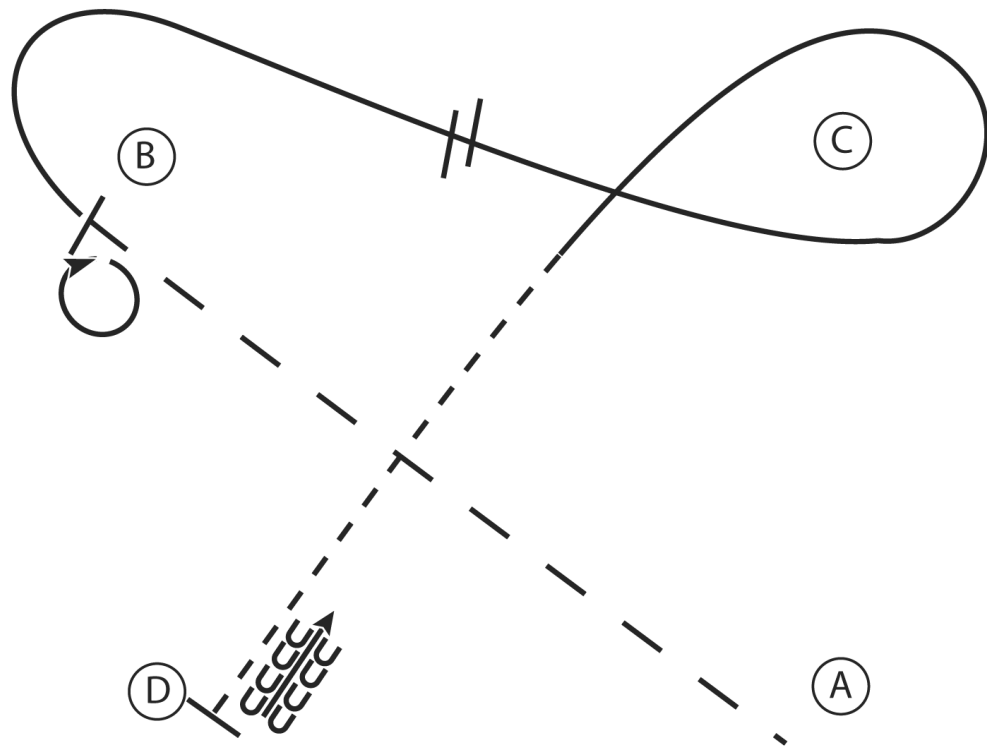

1. Extend the jog A to B
2. Stop at B and perform a 360 degree turn to the right
3. Lope on the right lead around B
4. Half way between B and C change leads and continue to and around C
5. Jog halfway between C and D
6. At D stop and back

Walk
Jog	-----
Extended Jog	-----
Lope	————
Leg Yield	
Lead Change	↘
Back	←
Marker	Ⓚ
Sidepass	←-----→

[WH/2-27]

Pattern Provided by:
Libby Michaud

Nebraska Quarter Horse Labor Day

Horsemanship (Level 1 Youth and Amateur)

Show Date: Sunday, September 4th, 2022

www.HorseShowPatterns.com

www.HorseShowPatterns.com

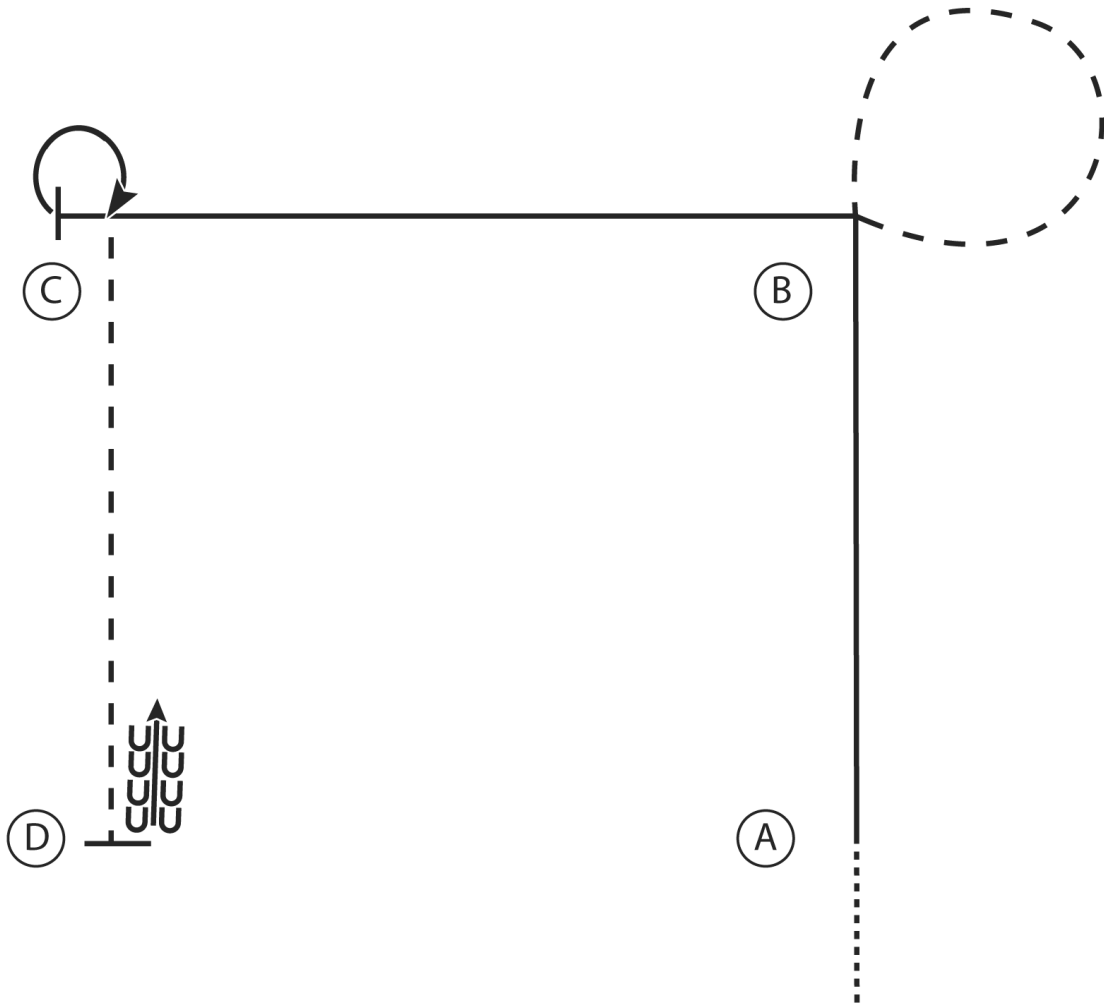

1. Walk to A
2. Lope on the right lead to B
3. At B extend the jog in a circle to the right
4. At B lope on the left lead to C
5. At C stop and perform a 270 degree turn to the right
6. Jog to D
7. At D stop and back 4 steps

Walk	
Jog	
Extended Jog	
Lope	
Leg Yield	
Lead Change	
Back	
Marker	
Sidepass	

[WH/2-50]

Pattern Provided by:
Libby Michaud

Nebraska Quarter Horse Labor Day

Horsemanship (Small Fry, Youth and Amateur Walk/Trot)

Show Date: Sunday, September 4th, 2022

w w w . H o r s e S h o w P a t t e r n s . c o m

w w w . H o r s e S h o w P a t t e r n s . c o m

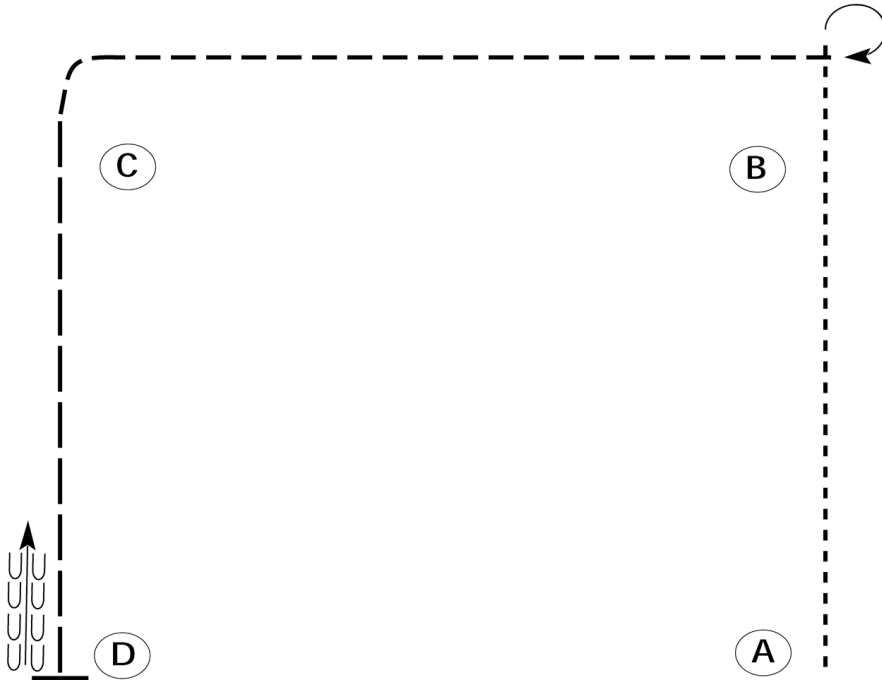

Be ready at A.

1. Walk from A to B.
2. Stop past B and execute a 270 degree turn to the right.
3. Jog from B around C.
4. Extend the jog from C to D.
5. Stop at D and back one horse length.

Please exit at a jog.

Walk	-----
Jog	-----
Extended Jog	-----
Lope	—————
Leg Yield	
Lead Change	—/—
Back	←←←←←
Marker	⊙ B
Sidepass	←-----→

[WH/WT-23]

Pattern Provided by:

Libby Michaud

Nebraska Quarter Horse Labor Day Equitation (Level 1, Youth and Amateur)

Show Date: Sunday, September 4th, 2022

www.HorseShowPatterns.com

www.HorseShowPatterns.com

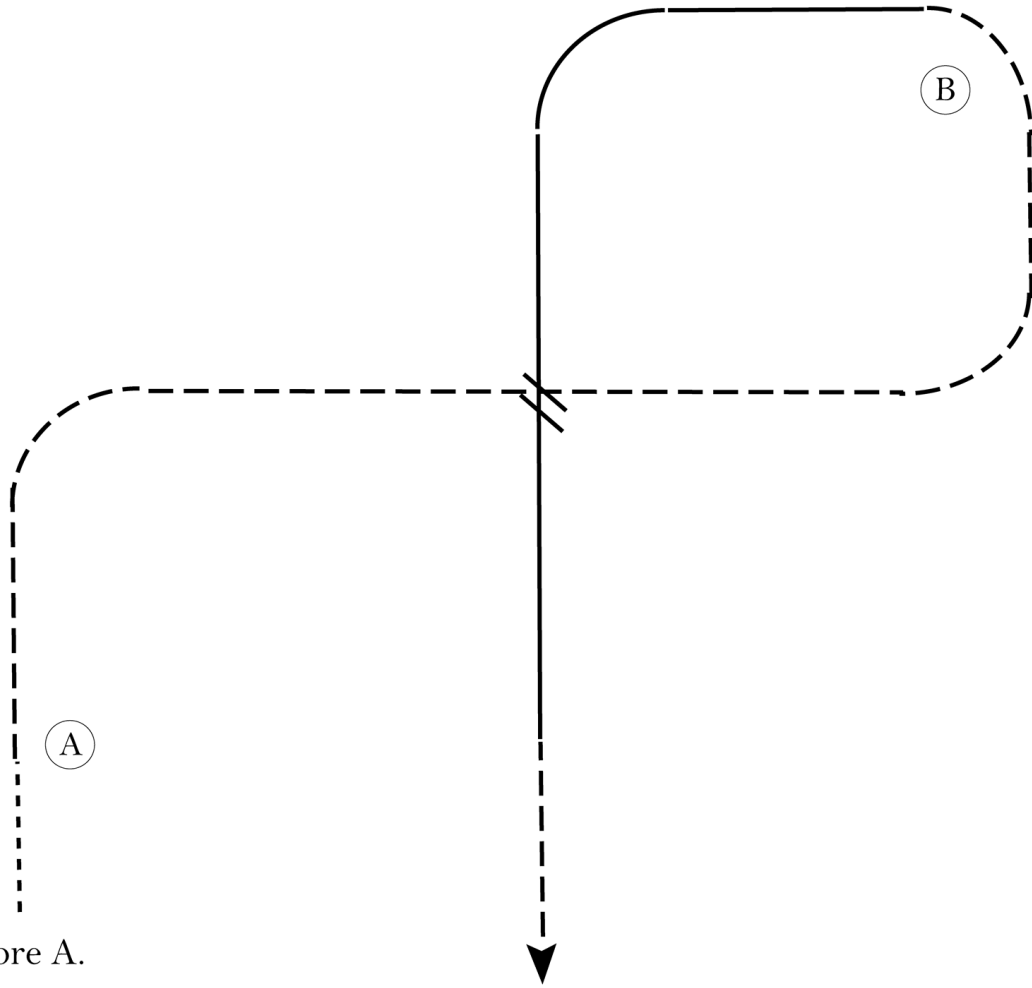

Be ready before A.

1. Walk to A.
2. Posting trot on the left diagonal to center of pattern.
3. Change diagonals at center. Trot on the right diagonal to B.
4. Canter on the left lead to center of pattern.
5. Change leads at center. Canter on right lead until even with A.
6. Sitting trot when even with A. Pattern is over after trotting 3 strides past A.

Follow the instructions of your ring steward.

Walk	-----
Trot	- - - - -
Extended Trot	-----
Canter	—————
Leg Yield	
Lead Change	↘
Back	←←←←←
Marker	⊙
Sidepass	←-----→
Hand Gallop	-----

[HSE/2-66]

Pattern Provided by:
Libby Michaud

Open Reining Jr/Sr

Show Date: Sunday, September 4th

REINING PATTERN I

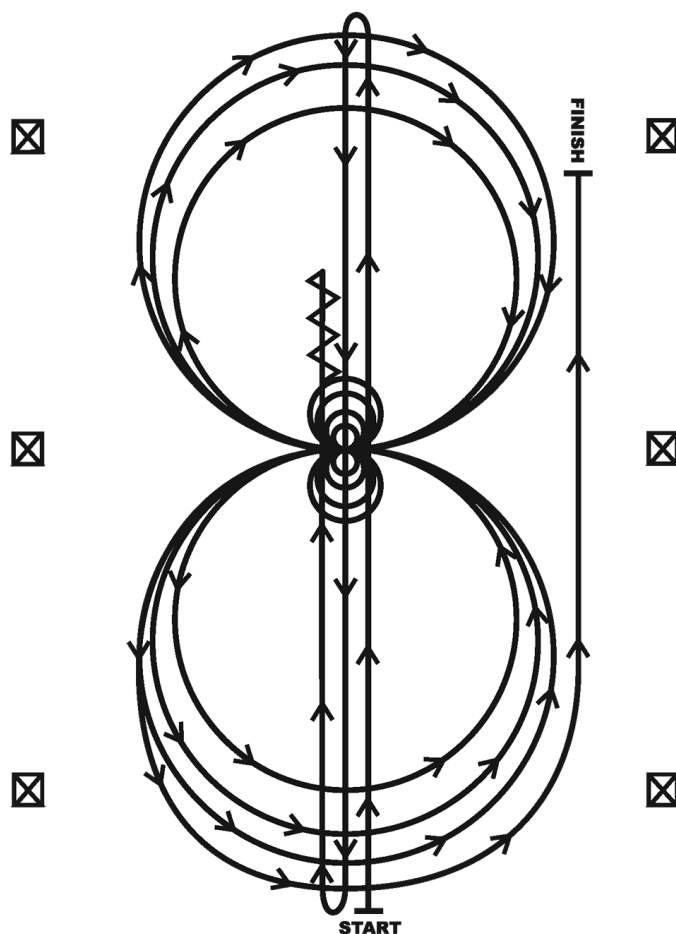

1. Run at speed to the far end of the arena past the endmarker and do a left rollback—no hesitation.
2. Run to the opposite end of the arena past the end marker and do a right rollback—no hesitation.
3. Run past the center marker and do a sliding stop. Back up to center of the arena or at least ten feet (three meters). Hesitate.
4. Complete four spins to the right. Hesitate.
5. Complete four and one-quarter spins to the left so that horse is facing left wall or fence. Hesitate.
6. Beginning on the left lead, complete three circles to the left: the first circle large and fast; the second circle small and slow; the third circle large and fast. Change leads at the center of the arena.
7. Complete three circles to the right: the first circle large and fast; the second circle small and slow; the third circle large and fast. Change leads at the center of the arena.
8. Begin a large circle to the left but do not close this circle. Run straight up the right side of the arena past the center marker and do a sliding stop at least twenty feet (six meters) from wall or fence. Hesitate to demonstrate the completion of the pattern.

[R/AQHAP-1]

Pattern Provided by:

Judges

Amateur/ Youth

Show Date: Sunday, September 4th

REINING PATTERN 3

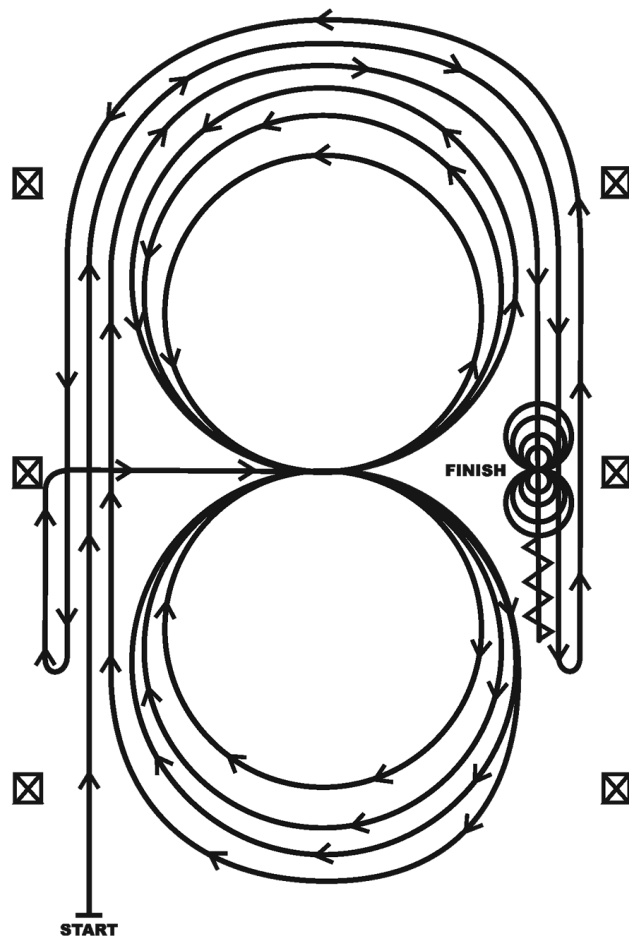

1. Beginning, lope straight up the left side of the arena, circle the top end of the arena, and staying at least twenty feet (six meters) from the walls or fence, run straight down the opposite or right side of the arena past the center marker and do a left rollback—no hesitation.
2. Continue straight up the right side of the arena circle back around the top of the arena, and staying at least twenty feet (six meters) from the walls or fence, run straight down the left side of the arena past the center marker and do a right rollback—no hesitation.
3. Continue up the left side of the arena to the center marker. At the center marker, the horse should be on the right lead. Guide the horse to the center of the arena on the right lead and complete three circles to the right: the first two circles large and fast; the third circle small and slow. Change leads at the center of the arena.
4. Complete three circles to the left: the first two circles large and fast; the third circle small and slow. Change leads in the center of the arena.
5. Begin a large circle to the right but do not close this circle. Continue up the left side of the arena, circle the top of the arena, and staying at least twenty feet (six meters) from the walls or fence, run straight down the opposite or right side of the arena past the center marker and do a sliding stop. Back up at least ten feet (three meters). Hesitate.
6. Complete four spins to the right. Hesitate.
7. Complete four spins to the left. Hesitate to demonstrate completion of the pattern.

[R/AQHAP-3]

Pattern Provided by:

Judges