

NQHA Hall of Fame Show

Level 1 Yth & Level 1 AM (All Judges)

Show Date: Friday, May 14th

Showmanship

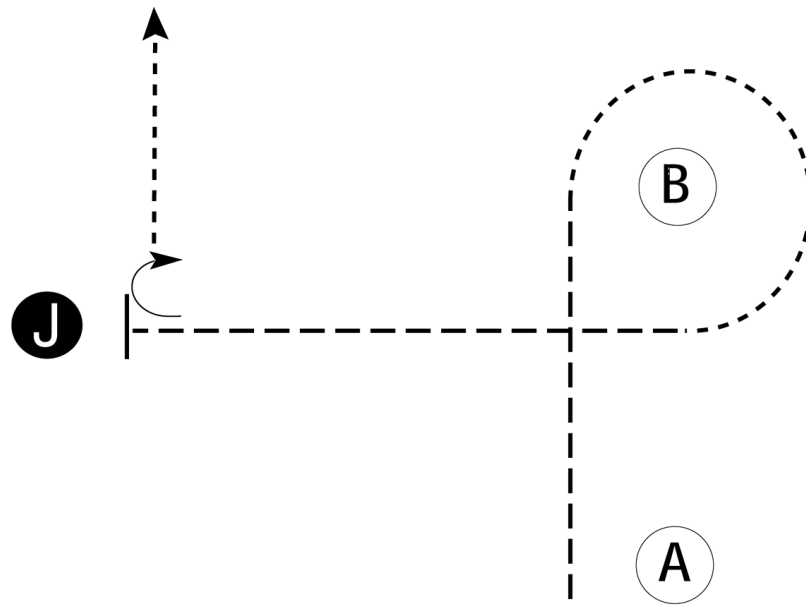

Be ready at A.

1. Trot from A to B.
2. Walk around B.
3. Trot from B to judge.
4. Stop and set up for inspection.
5. When dismissed, perform a 90 degree turn and walk away.

Follow the instructions of your ring steward.

| | |
|--------|-----------|
| Walk | ----- |
| Trot | - - - - - |
| Back | ← |
| Marker | ⊙ B |
| Judge | ● J |

[S/1-55]

Pattern Provided by:

Judges

NQHA Hall of Fame Show

Youth, Amateur & Select (All Judges)

Show Date: Friday, May 14th

Showmanship

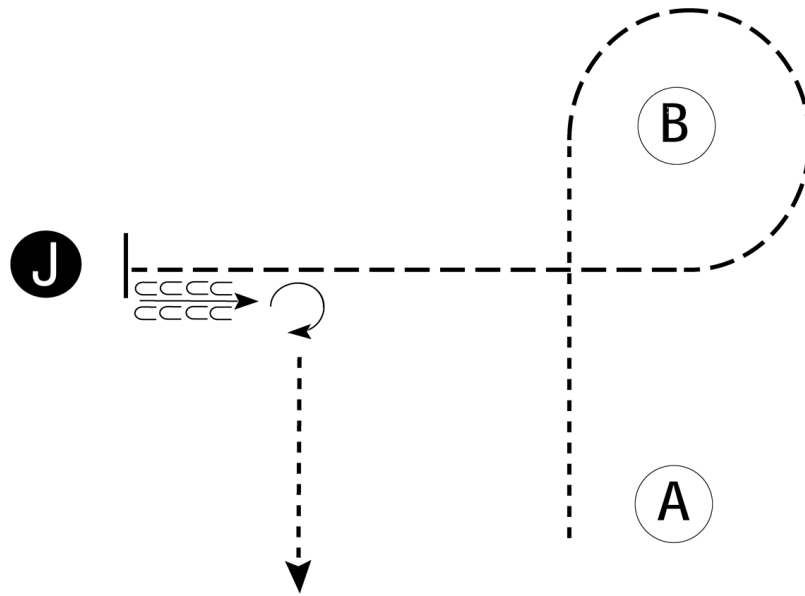

Be ready at A.

1. Walk from A to B.
2. Trot around B and to judge.
3. Stop and set up for inspection.
4. When dismissed, back approximately one horse length.
5. Perform a 270 degree turn and walk away.

Please exit the arena at the direction of the ring steward.

| | |
|--------|-----------|
| Walk | ----- |
| Trot | - - - - - |
| Back | ← |
| Marker | ⊙ B |
| Judge | ● J |

[S/3-55]

Pattern Provided by:

Judges

NQHA Hall of Fame Show

Small Fry/Walk Trot (All Judges)

Show Date: Friday, May 14th

Showmanship

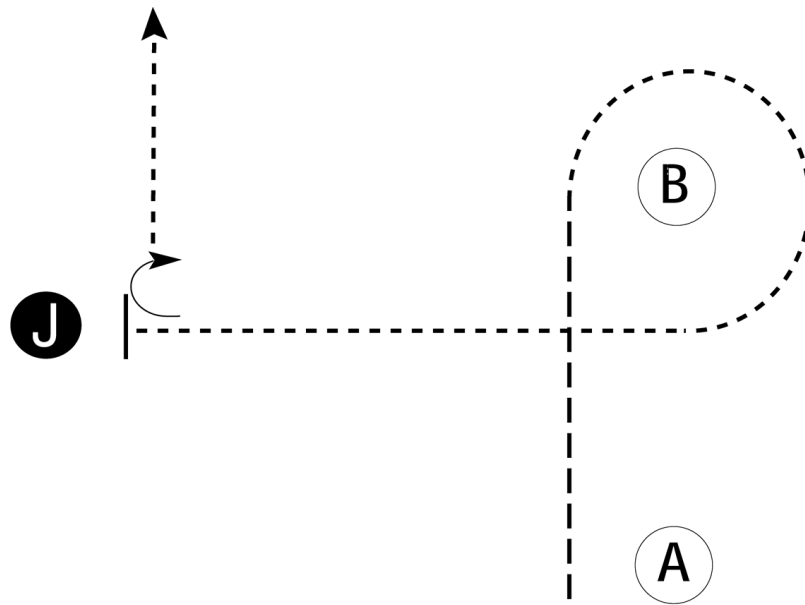

Be ready at A.

1. Trot from A to B.
2. Walk around B and to judge.
3. Stop and set up for inspection.
4. When dismissed, perform a 90 degree turn and walk away.

Follow the instructions of your ring steward.

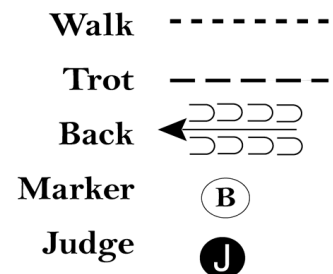

[S/WT-55]

Pattern Provided by:

Judges

Saturday All Trail (except SF / Walk Trot)

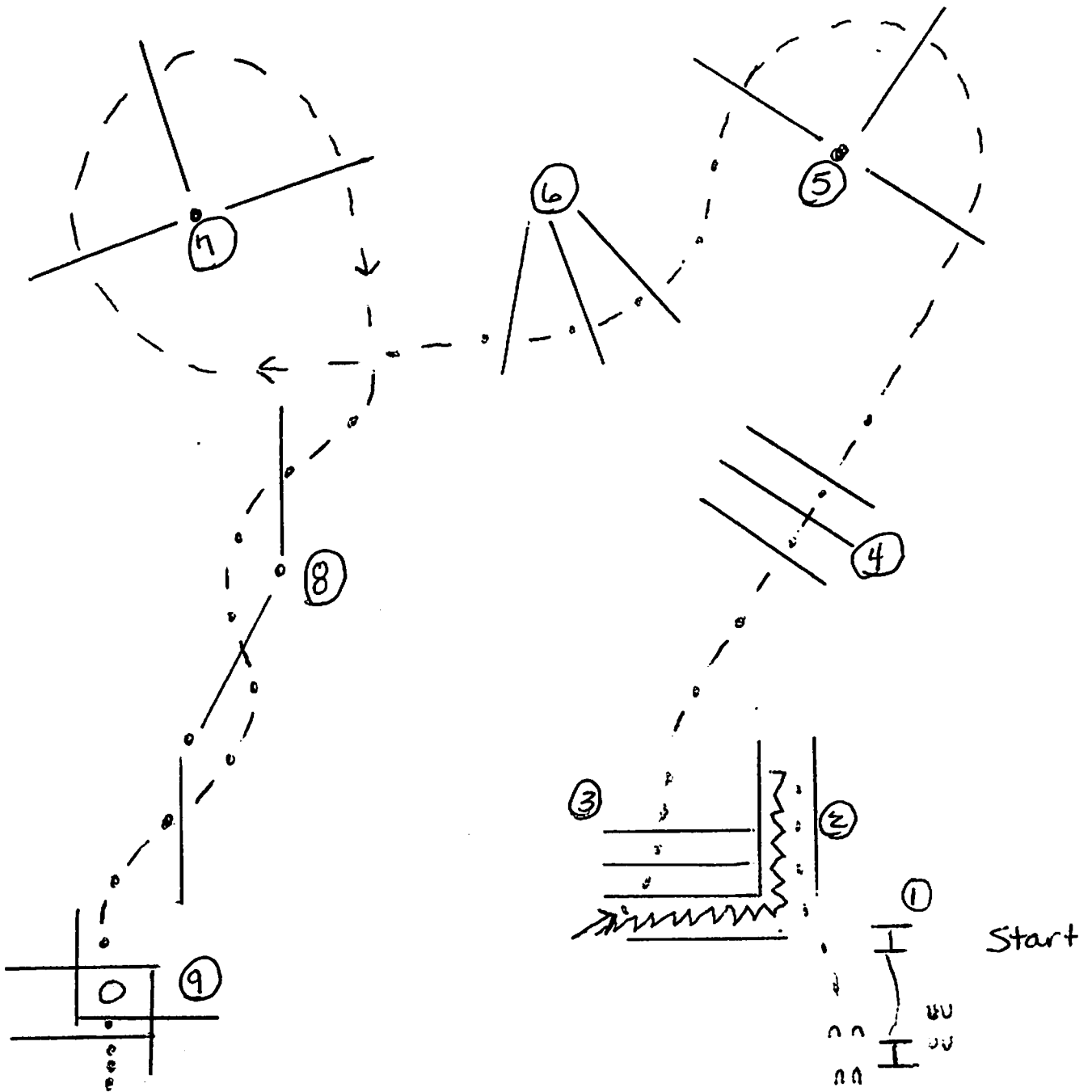

- ① RH Rope gate walk over pole
- ② Walk into chute, back chute
- ③ Walk Poles
- ④ Jog poles
- ⑤ L L Lope
- ⑥ Jog poles
- ⑦ RL Lope
- ⑧ Jog serpentine
- ⑨ Walk into box 360° turn either way, walk out

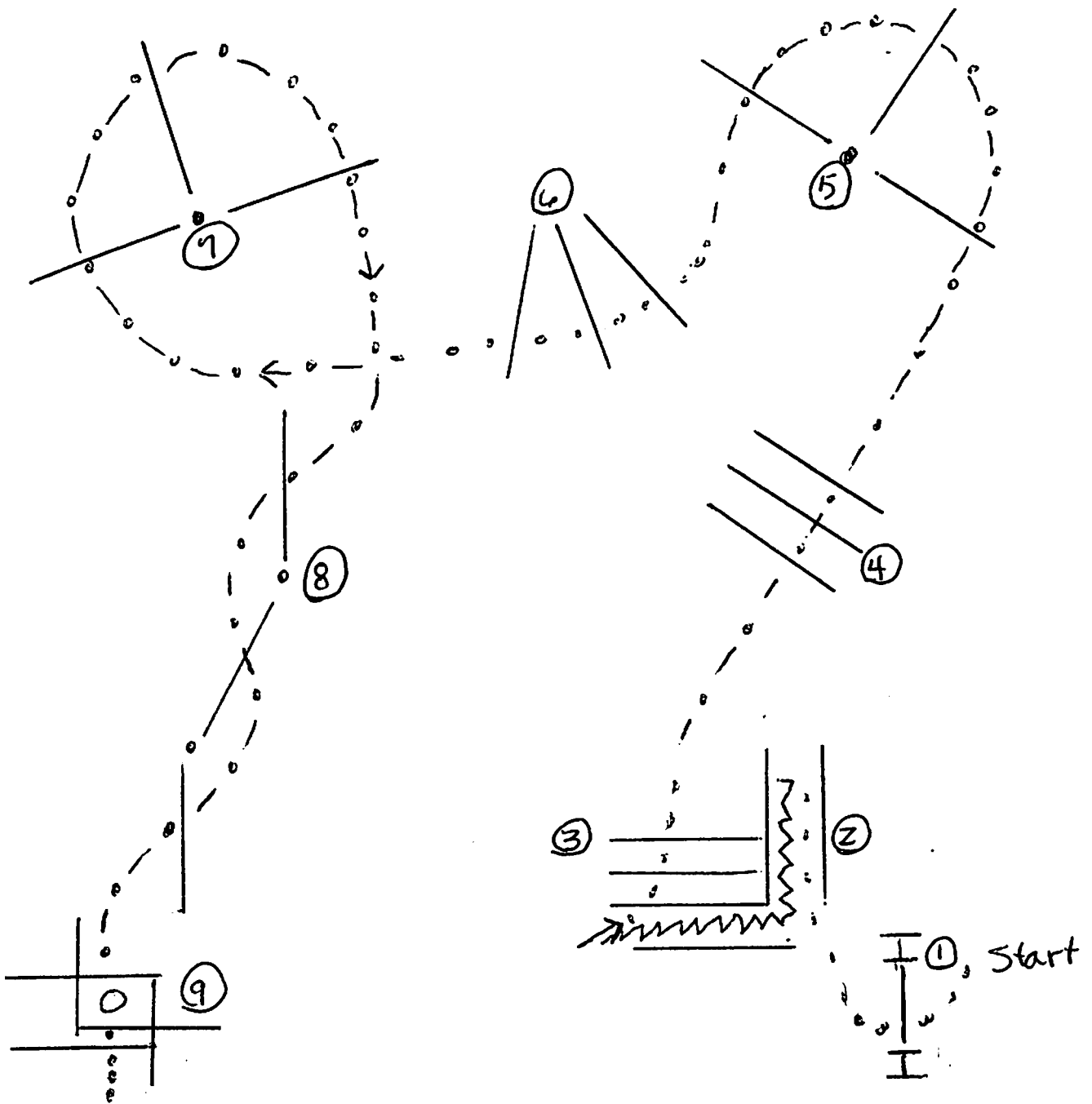

- ① Walk through gate over pole
- ② Walk into chute, back chute
- ③ Walk over poles
- ④ Jog 3 poles
- ⑤ Jog poles
- ⑥ Walk over 3 poles
- ⑦ Jog poles
- ⑧ Jog serpentine
- ⑨ Walk into box 360° turn either way, walk out

NQHA Hall of Fame Show

Youth, Amateur & Select (Judges Arbo & Barry)

Show Date: Saturday, May 15th
Hunt Seat Equitation

w w w . H o r s e S h o w P a t t e r n s . c o m

w w w . H o r s e S h o w P a t t e r n s . c o m

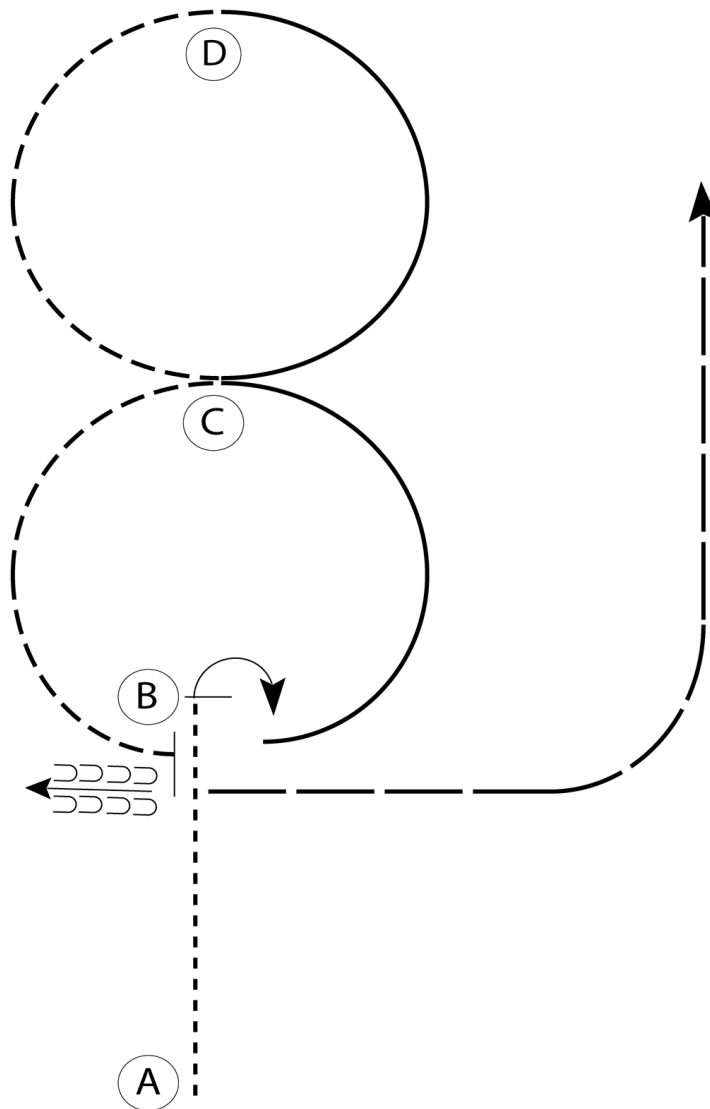

1. Walk from A to B
2. At B stop and perform a 90 turn on the forehand to the right
3. Canter on the left lead to C
4. Posting trot from C to D
5. At D canter on the right lead to C
6. Posting trot from C to B
7. At B stop and back one horse length
8. Hand gallop to the exit

| | |
|---------------|-----------|
| Walk | ----- |
| Trot | - - - - - |
| Extended Trot | ----- |
| Canter | ----- |
| Leg Yield | |
| Lead Change | ↘ |
| Back | ←←←←← |
| Marker | (B) |
| Sidepass | ←-----→ |
| Hand Gallop | ----- |

[HSE/1-26]

Pattern Provided by:

Judges

NQHA Hall of Fame Show

Level 1 Yth & Level 1 Am (Judges Arbo & Barry)

Show Date: Saturday, May 15th
Horsemanship

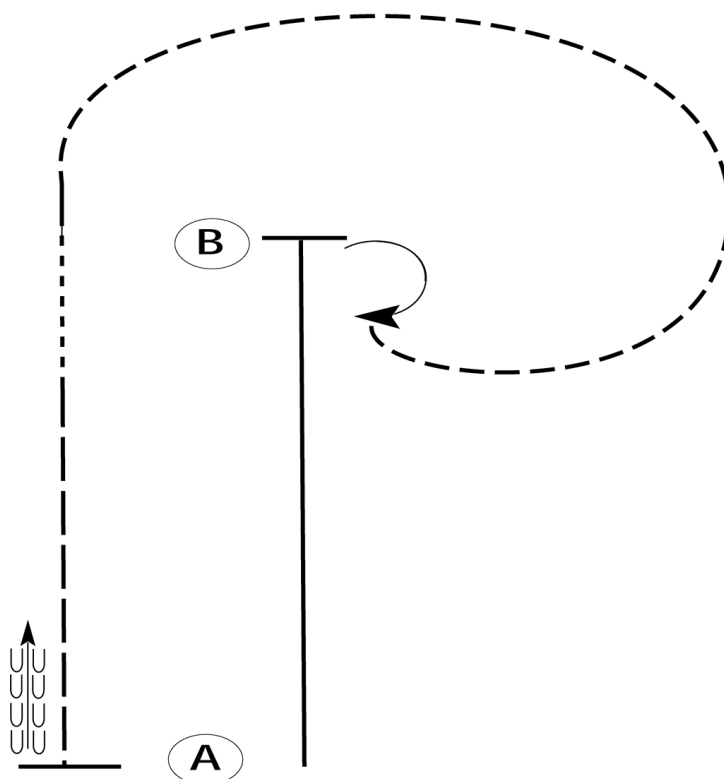

Be ready at A.

1. Lope on the right lead to B.
2. Turn 180 degrees to the right.
3. Jog back around to B.
4. At B, break to the walk.
5. Walk approximately 10 feet.
6. Extend the jog to A.
7. Stop at A and back approximately one horse length.

Follow the instructions of your ring steward.

| | |
|--------------|-------------|
| Walk | ----- |
| Jog | - - - - - |
| Extended Jog | — — — — |
| Lope | ————— |
| Leg Yield | |
| Lead Change | — / — |
| Back | ← — — — — |
| Marker | ⊙ B |
| Sidepass | ← — — — — → |

[WH/1-43]

Pattern Provided by:

Judges

w w w . H o r s e S h o w P a t t e r n s . c o m

w w w . H o r s e S h o w P a t t e r n s . c o m

NQHA Hall of Fame Show

Youth, Amateur & Select (Judges Arbo & Barry)

Show Date: Saturday, May 15th

Horsemanship

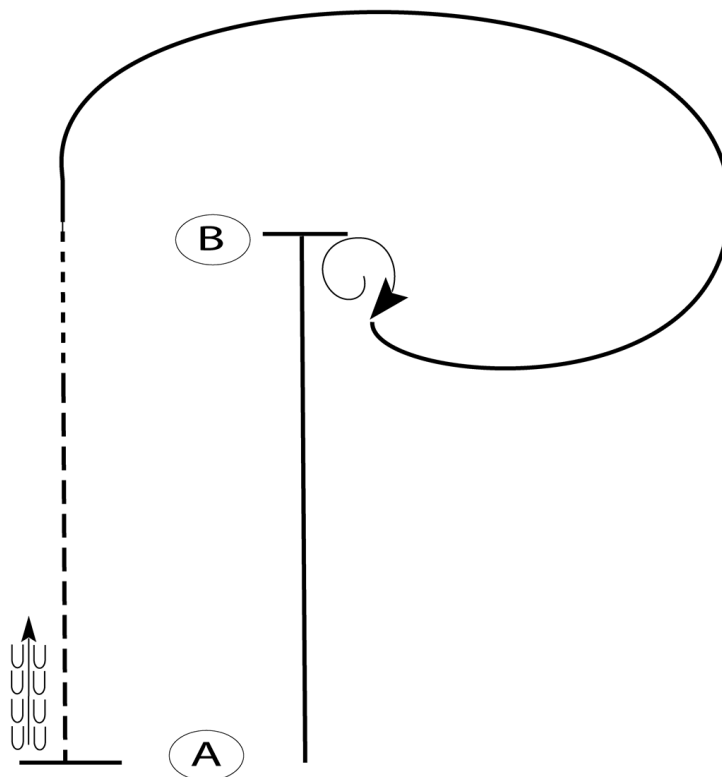

Be ready at A.

1. Lope on the right lead to B.
2. Turn 1 1/2 turns to the right.
3. Lope on the left lead back around to B.
4. At B, break to the walk.
5. Walk approximately 10 feet.
6. Extended jog to A.
7. Stop at A and back approximately one horse length.

Follow the instructions of your ring steward.

| | |
|--------------|------------------|
| Walk | ----- |
| Jog | ----- |
| Extended Jog | ----- |
| Lope | ----- |
| Leg Yield | |
| Lead Change | ↘ |
| Back | ← ↘ ↘ ↘ |
| Marker | ⊙ |
| Sidepass | ←-----→ |

[WH/3-43]

Pattern Provided by:

Judges

w w w . H o r s e S h o w P a t t e r n s . c o m

w w w . H o r s e S h o w P a t t e r n s . c o m

NQHA Hall of Fame Show

Small Fry/Walk Trot (Judges Arbo & Barry)

Show Date: Saturday, May 15th

Horsemanship

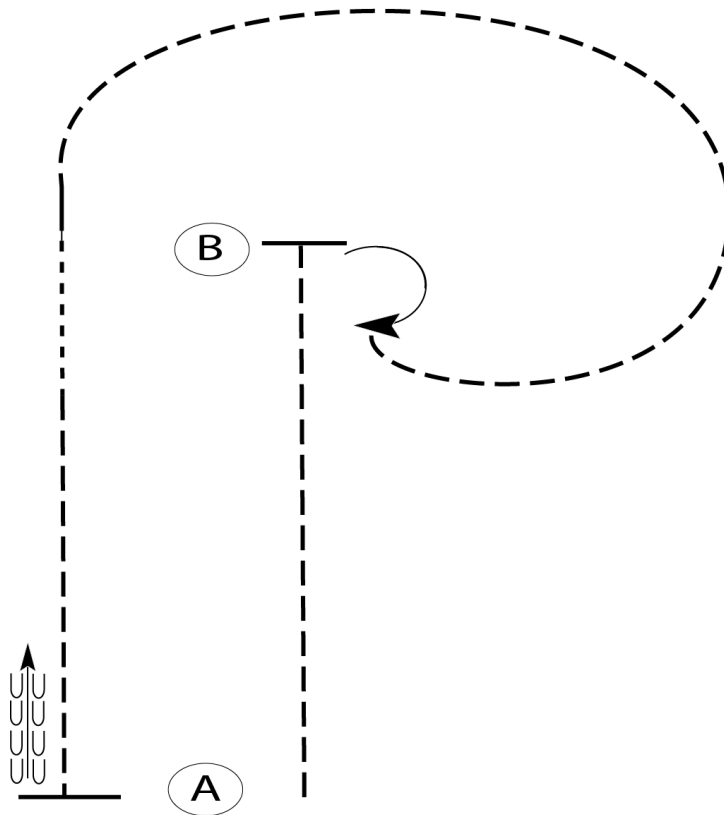

Be ready at A.

1. Jog to B.
2. Turn 180 degrees to the right.
3. Jog back around to B.
4. At B, break to the walk.
5. Walk approximately 10 feet.
6. Jog to A.
7. Stop at A and back approximately one horse length.

Follow the instructions of your ring steward.

Walk -----

Jog - - - - -

Extended Jog - - - - -

Lope _____

Leg Yield |||||

Lead Change

Back

Marker (B)

Sidepass

[WH/WT-43]

Pattern Provided by:

Judges

NQHA Hall of Fame Show

Level 1, Level 1 Yth & Level 1 Am (Judges Arbo & Barry)

Show Date: Saturday, May 15th

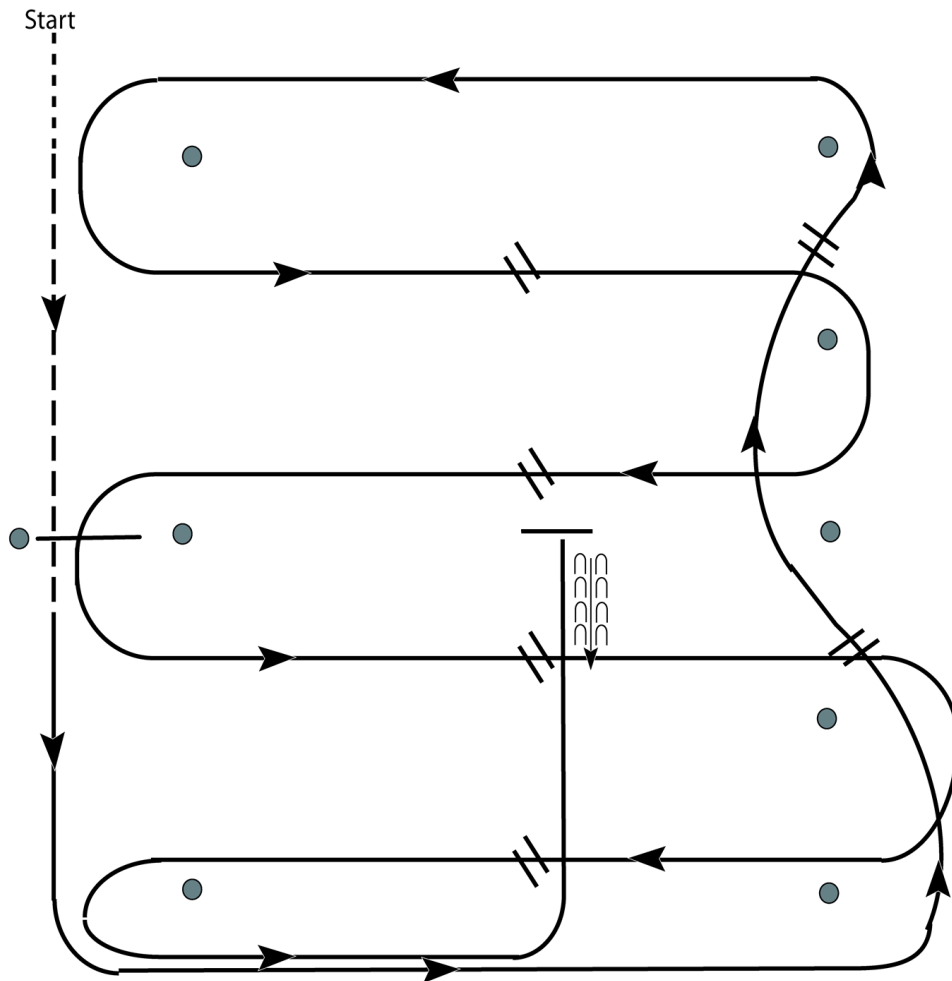

1. Walk at least 15' & jog over log.
2. Transition to left lead and lope around end.
3. First line change.
4. Second line change. Lope around end of arena
5. First crossing change.
6. Second crossing change.
7. Lope over log.
8. Third crossing change.
9. Fourth crossing change.
10. Lope up the center, stop and back.

[WR/GP-1]

Pattern Provided by:

Judges

NQHA Hall of Fame Show

All Western Riding except Level 1 classes (Judges Arbo & Barry)

Show Date: Saturday, May 15th

w w w . H o r s e S h o w P a t t e r n s . c o m

w w w . H o r s e S h o w P a t t e r n s . c o m

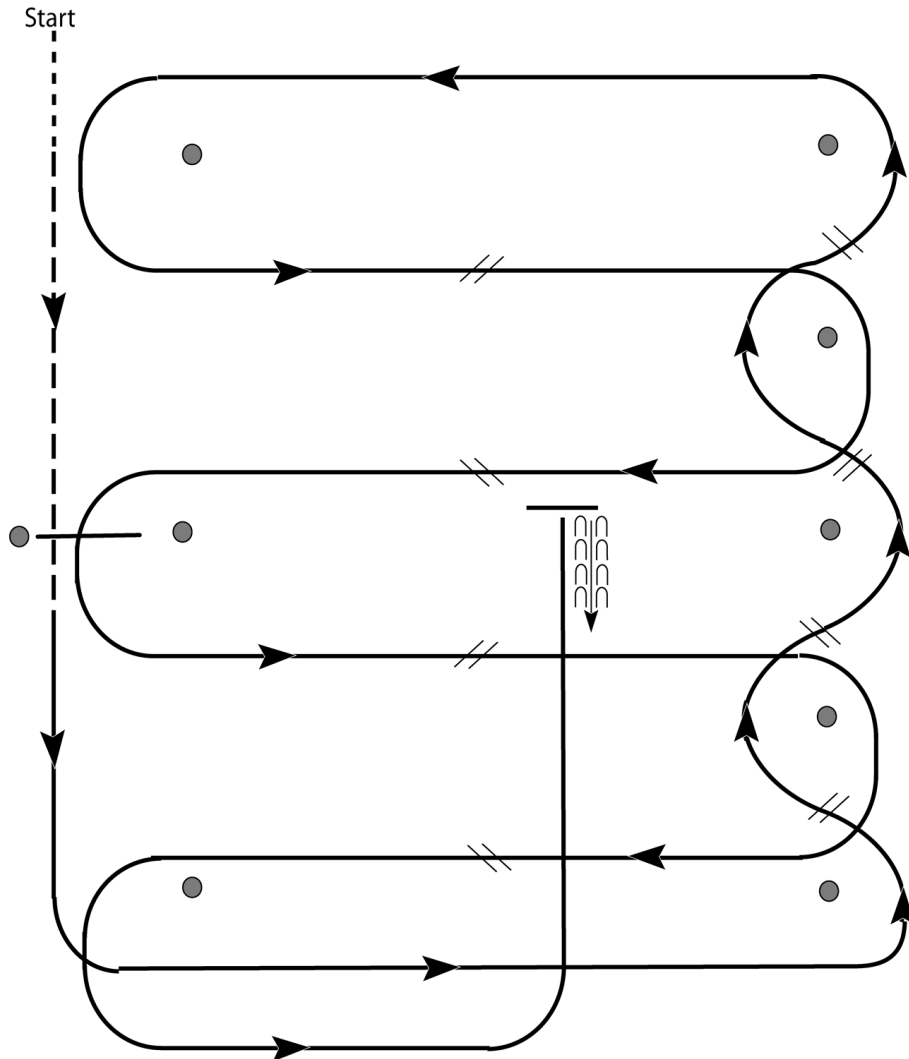

1. Walk and jog over log.
2. Transition to lope and lope around end.
3. First line change.
4. Second line change.
5. Third line change.
6. Fourth line change and lope around the end of the arena.
7. First crossing change.
8. Second crossing change.
9. Lope over log.
10. Third crossing change.
11. Fourth crossing change.
12. Lope up the center, stop and back.

[WR/OP-1]

Pattern Provided by:

Judges

2021 Hall of Fame Show

Working Cow/Boxing (All Working Cw/Boxing)

Show Date: Saturday May 15th

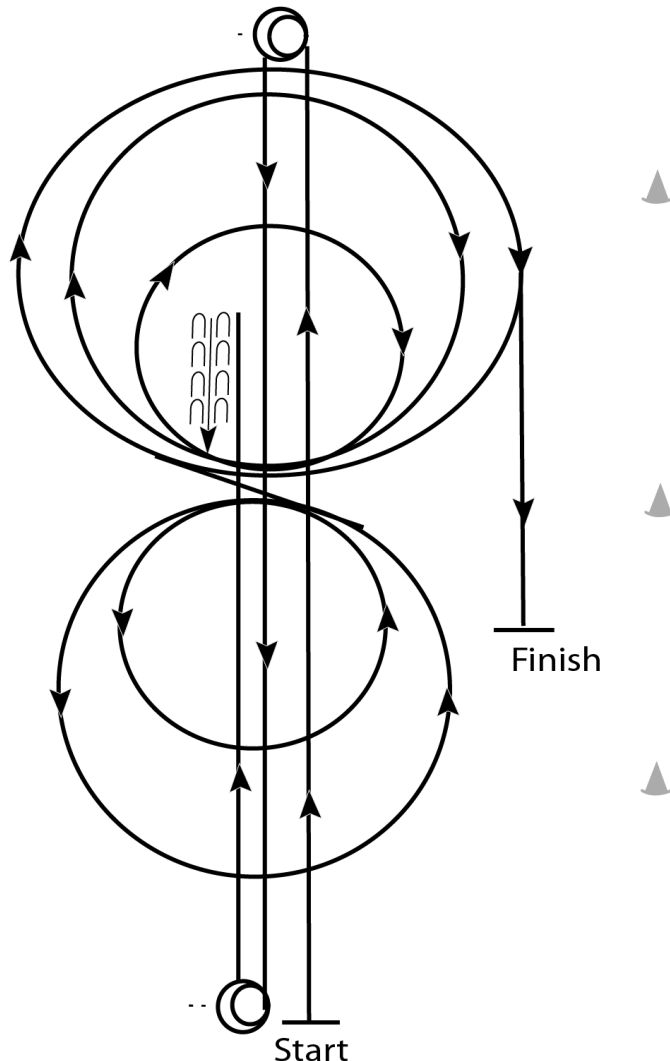

Pattern 4

1. Start at end of arena.
2. Run up center of arena past the end marker and come to a sliding stop. Complete 3 1/2 spins to the left.
3. Run to other end of arena past the end marker and stop. Complete 3 1/2 spins to the right.
4. Run past the center marker and stop.
5. Back at least 10 feet in a straight line.
6. Complete 1/4 turn to the left, hesitate. Beginning on the right lead, complete 2 circles to the right, the first one small and slow, and the second large and fast. Change leads at the center of the arena.
7. Complete one small, slow circle and one large, fast circle. Change leads to the right.
8. Run around end of arena to the other side, past center marker, at least 20 feet from fence and come to sliding stop.
9. Hesitate to complete pattern.

[NRCHAWC/4]

Pattern Provided by:

judges

2021 Hall of Fame Show

Reining (Level 1 Amateur/Youth)

Show Date: Saturday May 15th

REINING PATTERN 6

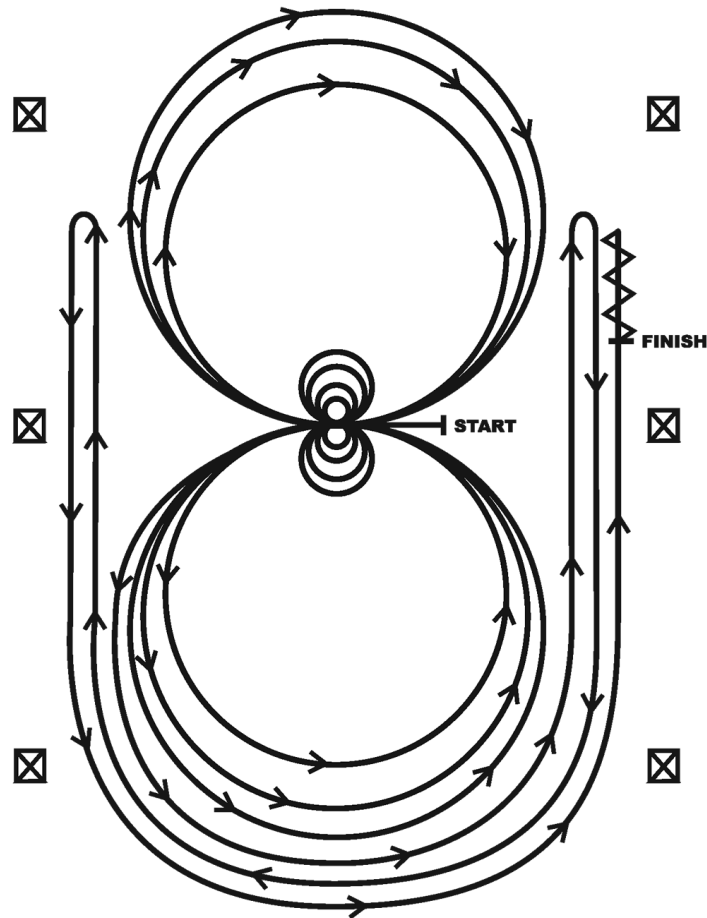

Horses may walk or jog to the center of arena. Horses must walk or stop prior to starting pattern. Beginning at the center of the arena facing the left wall or fence.

1. Complete four spins to the right. Hesitate.
2. Complete four spins to the left. Hesitate.
3. Beginning on the left lead, complete three circles to the left: the first two circles large and fast; the third circle small and slow. Change leads at the center of the arena.
4. Complete three circles to the right: the first two circles large and fast; the third circle small and slow. Change leads at the center of the arena.
5. Begin a large circle to the left but do not close this circle. Run up the right side of the arena past the center marker and do a right rollback at least twenty feet (six meters) from the wall or fence—no hesitation.
6. Continue back around previous circle but do not close this circle. Run up the left side of the arena past the center marker and do a left rollback at least twenty feet (six meters) from the wall or fence—no hesitation.
7. Continue back around previous circle but do not close this circle. Run up the right side of the arena past the center marker and do a sliding stop at least twenty feet (six meters) from the wall or fence. Back up at least ten feet (three meters). Hesitate to demonstrate the completion of the pattern.

[R/AQHAP-6]

Pattern Provided by:

judges

2021 Hall of Fame Show

AQHA Ranch Riding (All Level 1 Ranch Riding)

Show Date: Saturday May 15th

www.HorseShowPatterns.com

www.HorseShowPatterns.com

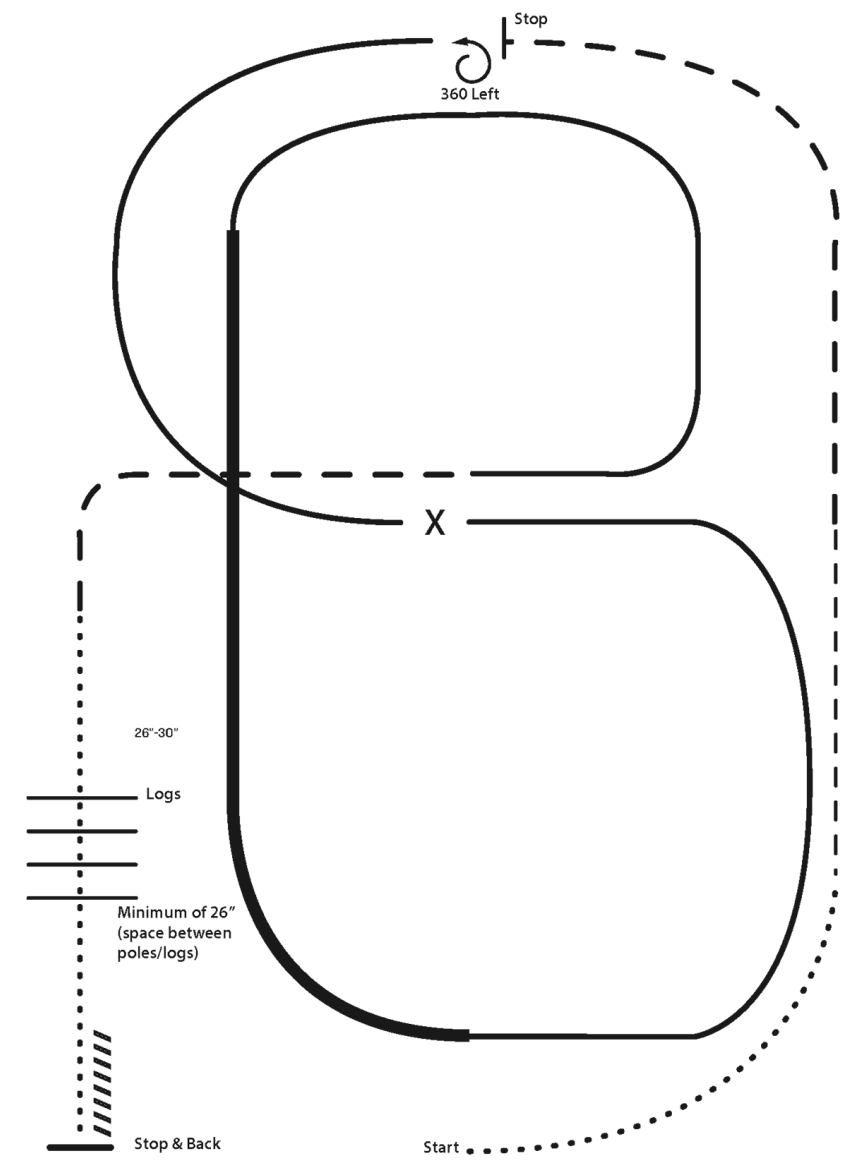

- X Lead Change
- Walk
- - - Trot
- - - Ext Trot
- — — Lope
- — — Ext Lope
- /////// Back

1. Walk
2. Trot
3. Extend the trot, at the top of the arena ,stop
4. 360 degree turn to the left
5. Left lead 1/2 circle, lope to the center
6. Change leads (simple or flying)
7. Right lead 1/2 circle
8. Extended lope up the long side of the arena (right lead)
9. Collect back to a lope around the top of the arena and back to center
10. Break down to an extended trot
11. Walk over logs
12. Stop and back

[RR/AQHA-1]

Pattern Provided by:

judges

2021 Hall of Fame Show

Reining (Open/Amateur/Youth/Select)

Show Date: Saturday May 15th

REINING PATTERN 11

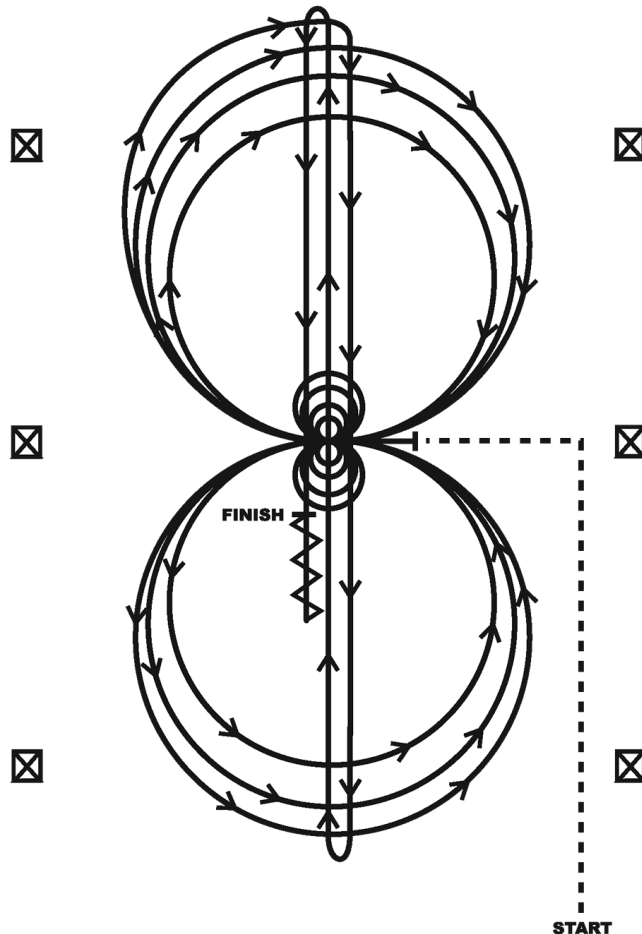

Horses must jog to the center of the arena. Horses must walk or stop prior to starting the pattern. Beginning at the center of the arena facing the left wall or fence.

1. Complete four spins to the left. Hesitate.
2. Complete four spins to the right. Hesitate.
3. Beginning on the right lead complete three circles to the right; the first circle small and slow; the next two circles large and fast. Change leads at the center of the arena.
4. Complete three circles to the left; the first circle small and slow; the next two circles large and fast. Change leads at the center of the arena.
5. Begin a large circle to the right, but do not close this circle. Run down the center of the arena past the end marker and do a right rollback—no hesitation.
6. Run up the middle to the opposite end of the arena past the end marker and do a left rollback—no hesitation.
7. Run past the center marker and do a sliding stop. Back up to the center of the arena or at least ten feet (three meters). Hesitate to demonstrate completion of the pattern.

[R/AQHAP-11]

Pattern Provided by:

judges

2021 Hall of Fame Show

Ranch Riding (Open/Amateur/Youth)

Show Date: Saturday May 15th

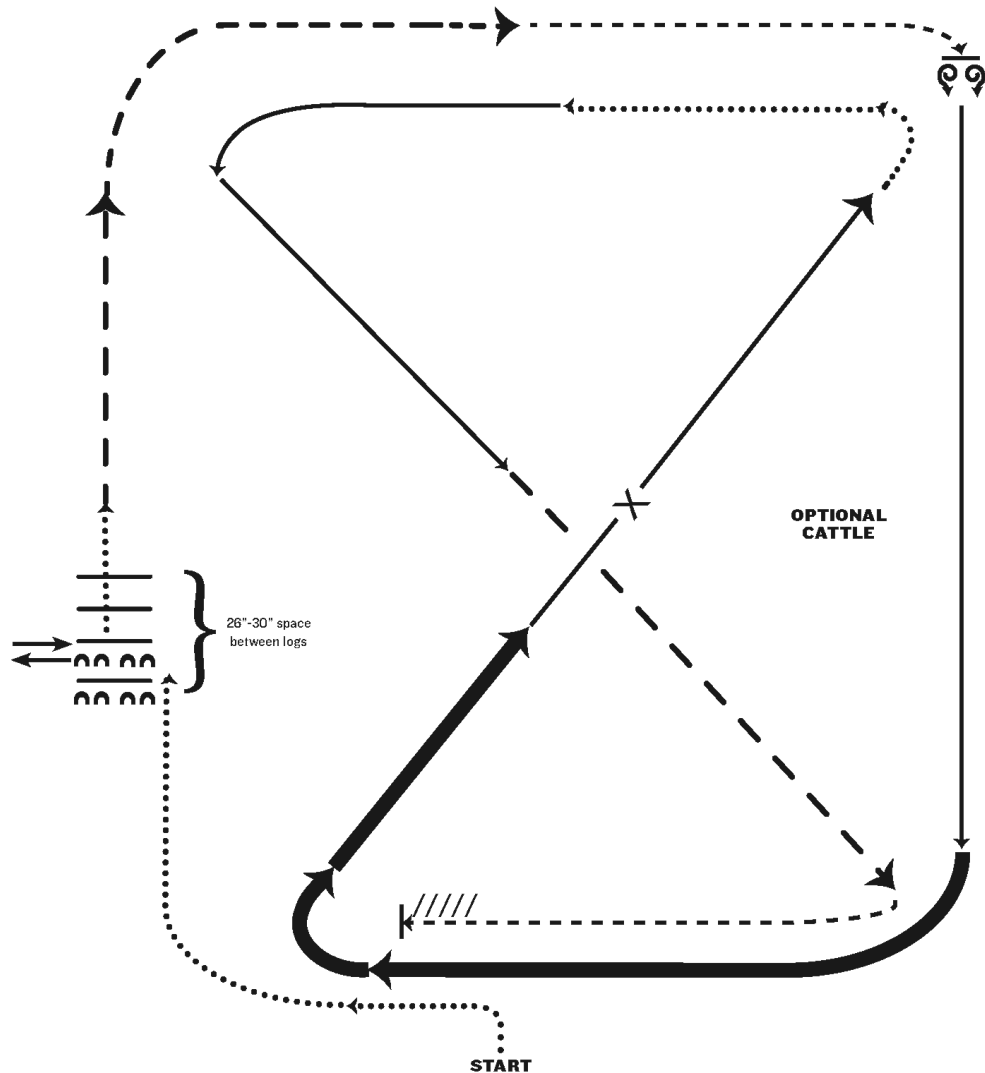

1. Walk
2. Side pass left across first log, side pass 1/2 way to right
3. Walk across logs
4. Extended trot
5. Trot
6. Stop, 360 degree turn each direction (either direction 1st) (L-R or R-L)
7. Lope right lead
8. Extended lope (right lead)
9. Collect lope, change leads (simple or flying)
10. Walk
11. Lope left lead
12. Extended trot
13. Trot
14. Stop and back

Note: The drawn description of this pattern is only intended for the general depiction of the pattern. Exhibitors should utilize the arena space to best exhibit their horses.

[RR/AQHA-8]

Pattern Provided by:

judges

www.HorseShowPatterns.com

www.HorseShowPatterns.com

Sunday All Trail
(except SF / walk Trot)

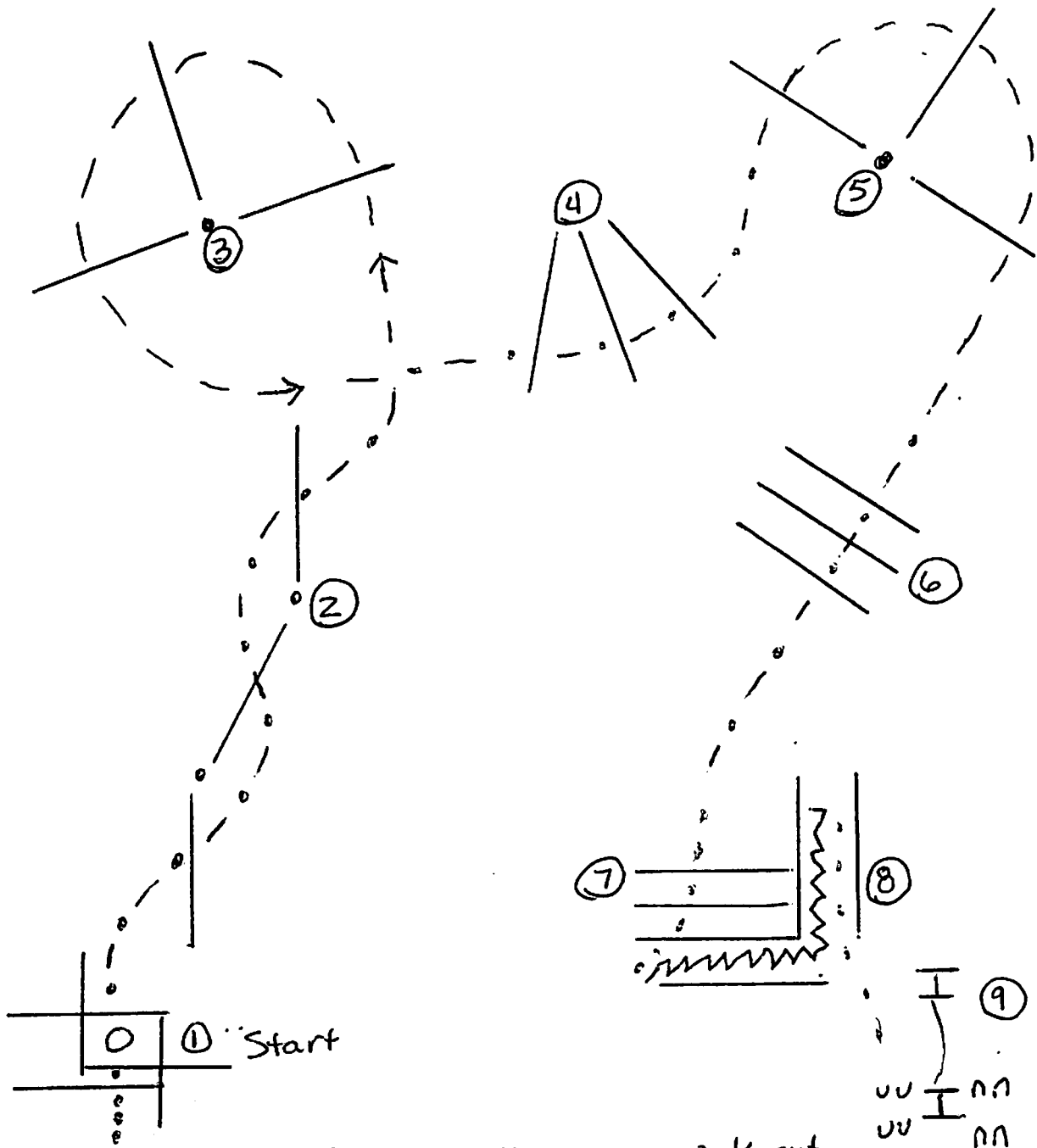

- ① Walk into box 360° turn either way, walk out
- ② log serpentine
- ③ LL Lope
- ④ log poles
- ⑤ RL Lope
- ⑥ log poles
- ⑦ Walk over poles
- ⑧ Back chute
- ⑨ Walk to gate, LH gate walk over pole

Sunday SF / Walk trot

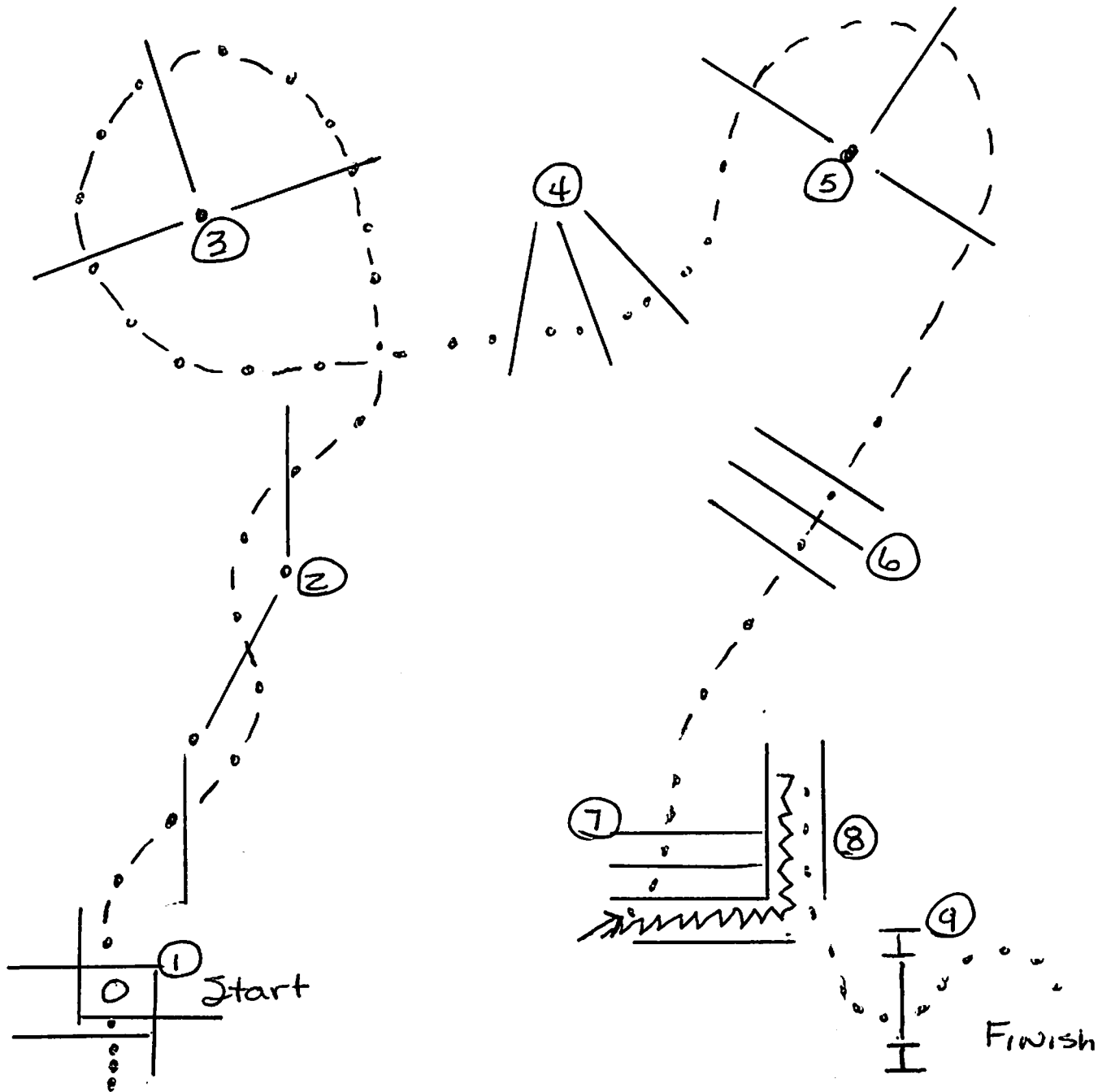

- ① Walk into box 360° turn either way, walk out
- ② Jog serpentine
- ③ Jog poles
- ④ Walk 3 poles
- ⑤ Jog poles
- ⑥ Jog 3 poles
- ⑦ Walk poles
- ⑧ Back chute
- ⑨ Walk through gate over pole

2021 Hall of Fame Show

Hunt Seat Equitation (Level 1 Amateur/Youth)

Show Date: Sunday May 16th

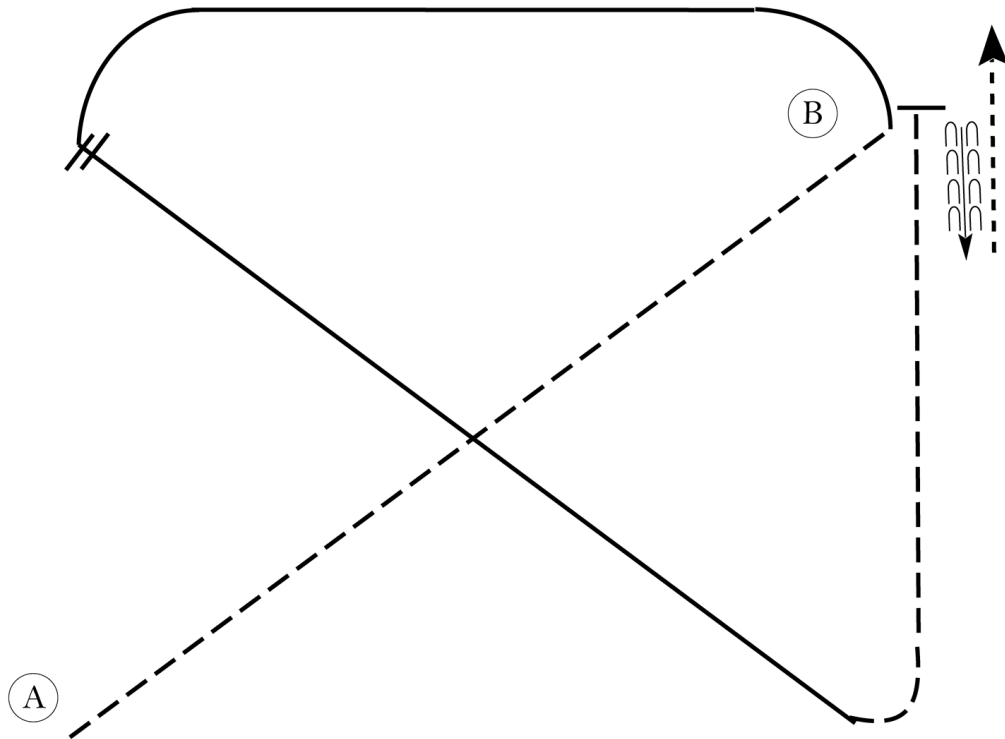

Be ready at A.

1. Sitting trot halfway to B.
2. Posting trot on the right diagonal to B.
3. Canter on the left lead from B across the arena..
4. Round the arena, then change leads.
5. Canter on the right lead on the diagonal.
6. Break to a trot on the left diagonal in a straight line to B.
7. Halt at B and back approximately one horse length.
8. Demonstrate a forward walk in a straight line from B for at least two horse lengths.

Follow the instructions of your ring steward.

| | |
|---------------|-----------|
| Walk | |
| Trot | - - - - - |
| Extended Trot | - - - - - |
| Canter | ————— |
| Leg Yield | |
| Lead Change | — / — |
| Back | ←←←←← |
| Marker | ⓑ |
| Sidepass | ←←←←← |
| Hand Gallop | ————— |

[HSE/2-61]

Pattern Provided by:

judges

2021 Hall of Fame Show

Hunt Seat Equitation (Youth/Amateur/Select)

Show Date: Sunday May 16th

www.HorseShowPatterns.com

www.HorseShowPatterns.com

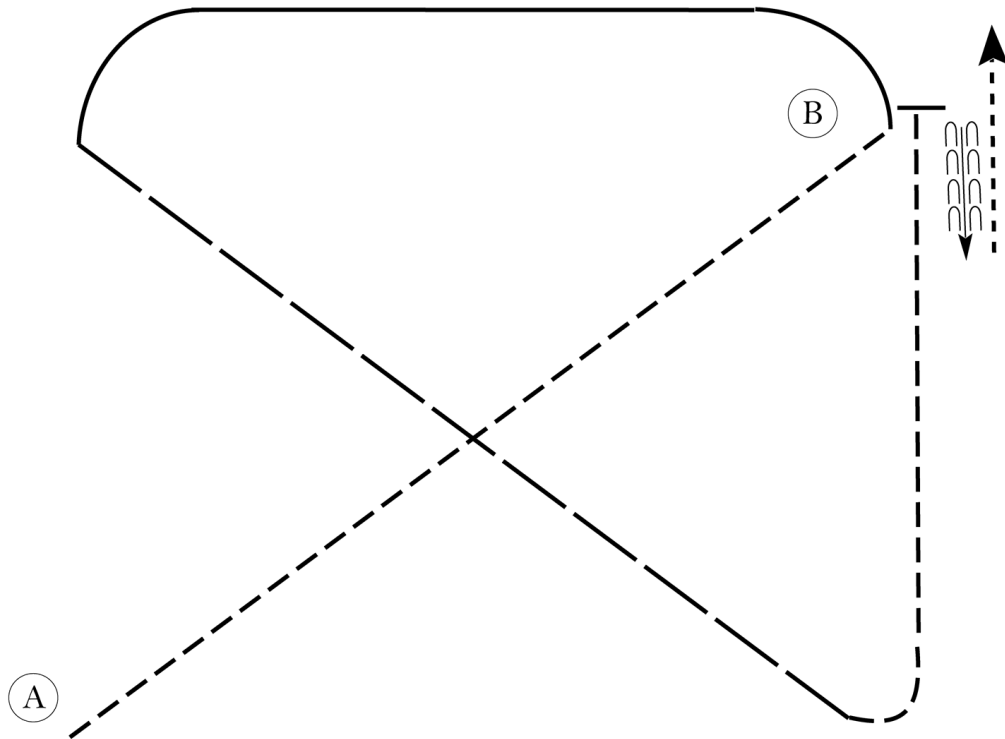

Be ready at A.

1. Sitting trot halfway to B.
2. Posting trot on the right diagonal to B.
3. Canter on the left lead from B across the arena..
4. Round the arena and move into a hand gallop on the diagonal.
5. Break to a trot on the left diagonal in a straight line to B.
6. Halt at B and back approximately one horse length.
7. Demonstrate a forward walk in a straight line from B for at least two horse lengths.

Follow the instructions of your ring steward.

| | |
|---------------|-------|
| Walk | |
| Trot | ----- |
| Extended Trot | ----- |
| Canter | ————— |
| Leg Yield | |
| Lead Change | —/— |
| Back | ←←←← |
| Marker | ⓑ |
| Sidepass | ←←←← |
| Hand Gallop | ————— |

[HSE/3-61]

Pattern Provided by:

judges

2021 Hall of Fame Show

Hunt Seat Equitation (Small Fry)

Show Date: Sunday May 16th

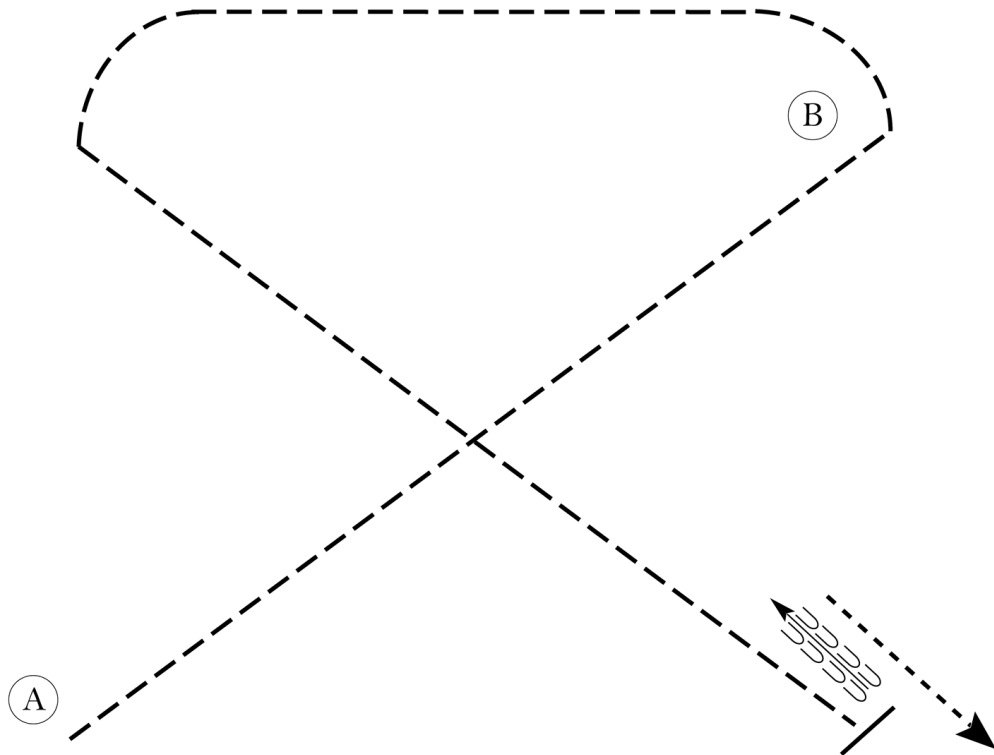

Be ready at A.

1. Sitting trot halfway to B.
2. Posting trot on the right diagonal to and around B.
3. Continue to trot on the right diagonal in a straight line and round the left side of arena.
4. After rounding the corner, change diagonals and post on the left diagonal across the arena toward the stop.
5. Halt when even with A and back approximately one horse length.
6. Demonstrate a walk for at least two horse lengths away from pattern.

| | |
|---------------|-------|
| Walk | ----- |
| Trot | ----- |
| Extended Trot | ----- |
| Canter | ----- |
| Leg Yield | |
| Lead Change | ↙↘ |
| Back | ←←← |
| Marker | ⊙ |
| Sidepass | ←---← |
| Hand Gallop | ----- |

Follow the instructions of your ring steward.

[HSE/WT-61]

Pattern Provided by:

judges

2021 Hall of Fame Show

Western Horsemanship (Level 1 Amateur/Youth)

Show Date: Sunday May 16th

w w w . H o r s e S h o w P a t t e r n s . c o m

w w w . H o r s e S h o w P a t t e r n s . c o m

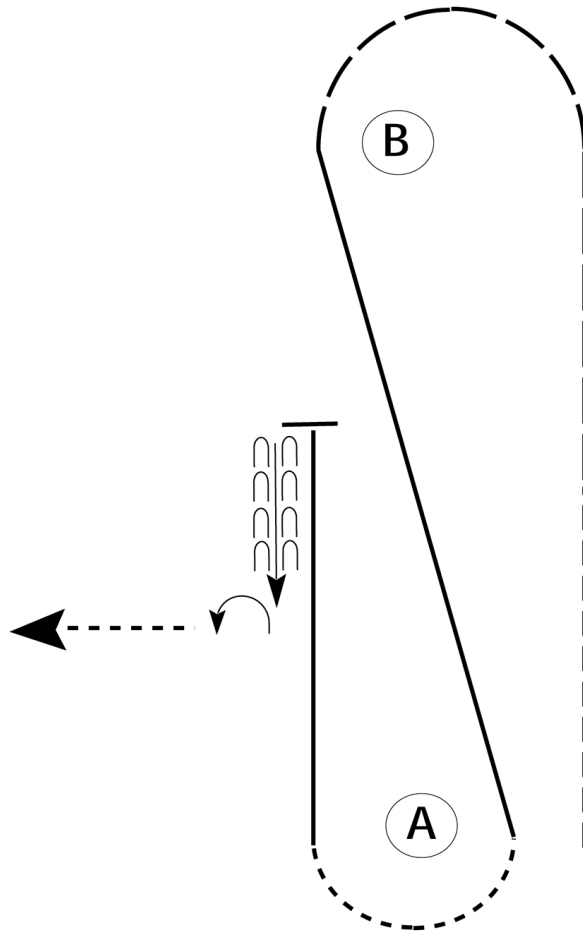

Be ready at A.

1. Jog halfway to B.
2. Extend the jog to and around B.
3. Lope on the left lead diagonally back to A.
4. Walk around A.
5. Lope on the right lead halfway to B.
6. Stop and back approximately two horse lengths.
7. Perform a 1/4 turn to the left.
8. Walk straight away.

Follow the instructions of your ring steward.

| | |
|--------------|-----------|
| Walk | ----- |
| Jog | - - - - - |
| Extended Jog | - - - - - |
| Lope | |
| Lead Change | ⌘ |
| Back | ← |
| Marker | Ⓚ |

[WH/2-86]

Pattern Provided by:

judges

2021 Hall of Fame Show

Western Horsemanship (Select/Amateur/Youth)

Show Date: Sunday May 16th

w w w . H o r s e S h o w P a t t e r n s . c o m

w w w . H o r s e S h o w P a t t e r n s . c o m

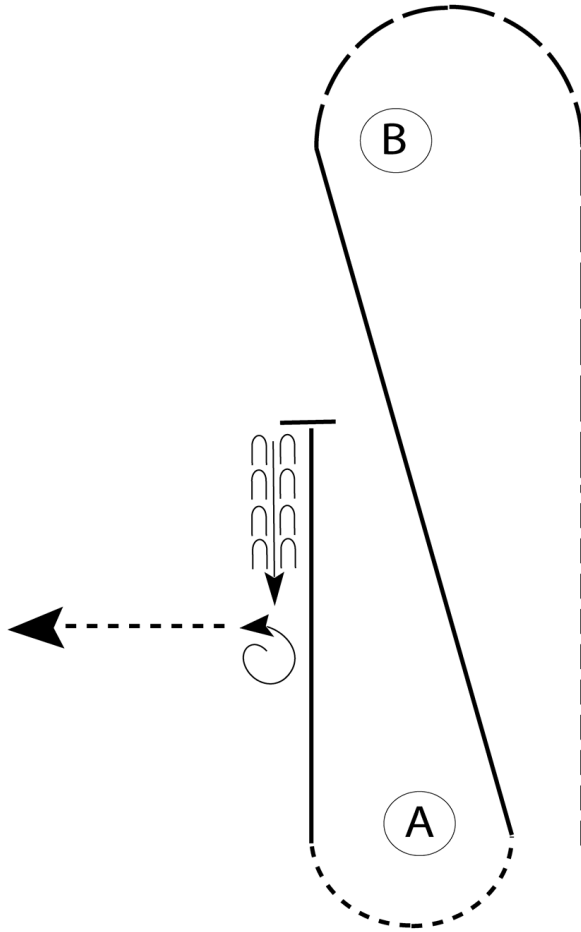

Be ready at A.

1. Jog halfway to B.
2. Extend the jog to and around B.
3. Lope on the left lead diagonally back to A.
4. Walk around A.
5. Lope on the right lead halfway to B.
6. Stop and back approximately two horse lengths.
7. Perform a 1 1/4 turn to the left.
8. Walk straight away.

Follow the instructions of your ring steward.

| | |
|--------------|-----------|
| Walk | ----- |
| Jog | - - - - - |
| Extended Jog | — — — — |
| Lope | |
| Lead Change | |
| Back | |
| Marker | (B) |

[WH/3-86]

Pattern Provided by:

judges

2021 Hall of Fame Show

Western Horsemanship (Small Fry/Level 1 W/T)

Show Date: Sunday May 16th

w w w . H o r s e S h o w P a t t e r n s . c o m

w w w . H o r s e S h o w P a t t e r n s . c o m

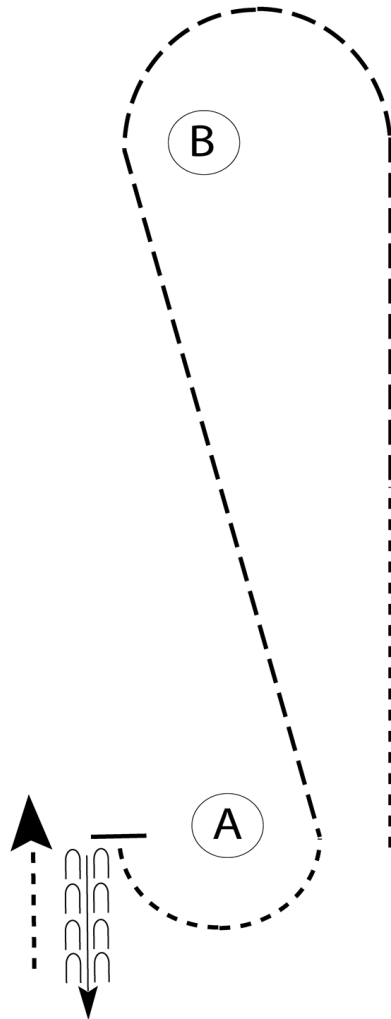

Be ready at A.

1. Walk halfway to B.
2. Jog to and around B.
3. Continue to jog diagonally back to A.
4. Walk around A.
5. Stop and back approximately two horse lengths.
6. Walk straight away.

Follow the instructions of your ring steward.

| | |
|--------------|-----------|
| Walk | ----- |
| Jog | - - - - - |
| Extended Jog | — — — — |
| Lope | |
| Lead Change | — / — |
| Back | ← — — — — |
| Marker | Ⓚ |

[WH/WT-86]

Pattern Provided by:

judges

2021 Hall of Fame Show

Western Riding (Select/Amateur/Youth/Open)

Show Date: Sunday May 16th

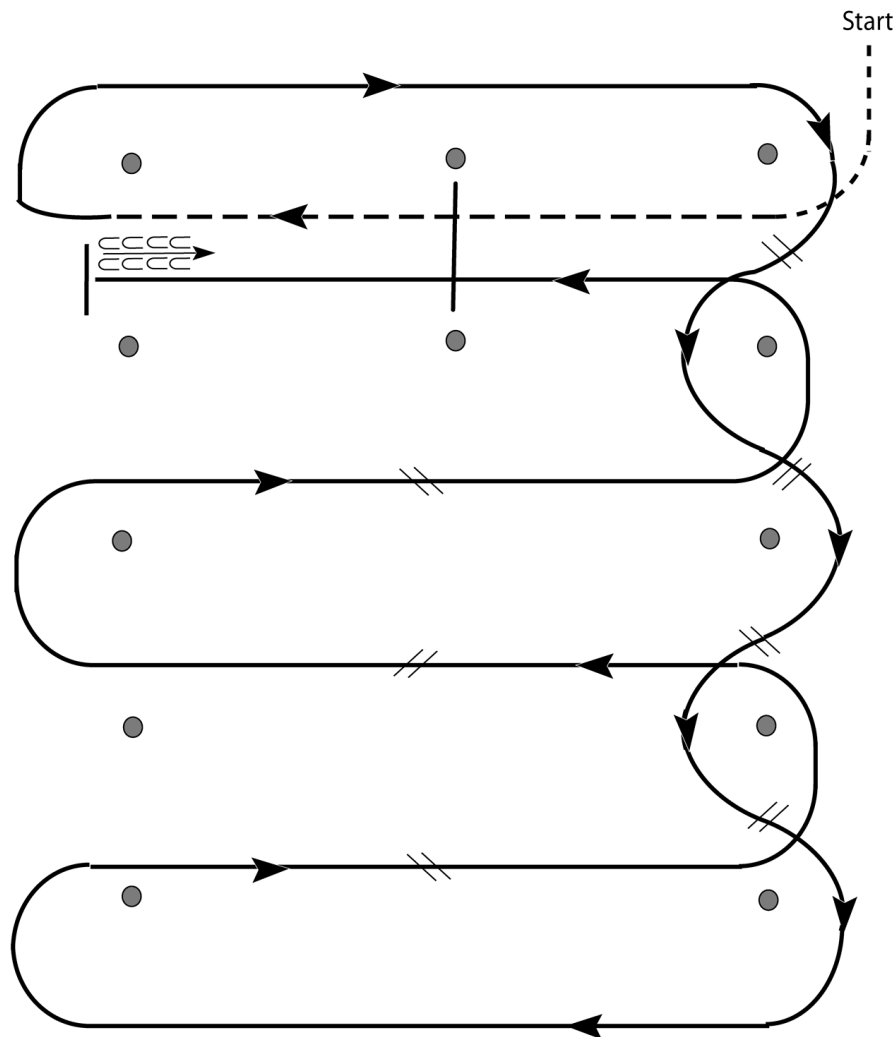

1. Walk, transition to jog, jog over log.
2. Transition to right.
3. First line change.
4. Second line change.
5. Third line change.
6. Fourth line change.
7. First crossing change.
8. Second crossing change.
9. Third crossing change.
10. Lope over log.
11. Lope, stop and back.

[WR/OP-4]

Pattern Provided by:

judges

NQHA Hall of Fame Show

All Working Cowhorse & Boxing Classes (Judges Arbo & Barry)

Show Date: Sunday, May 16th

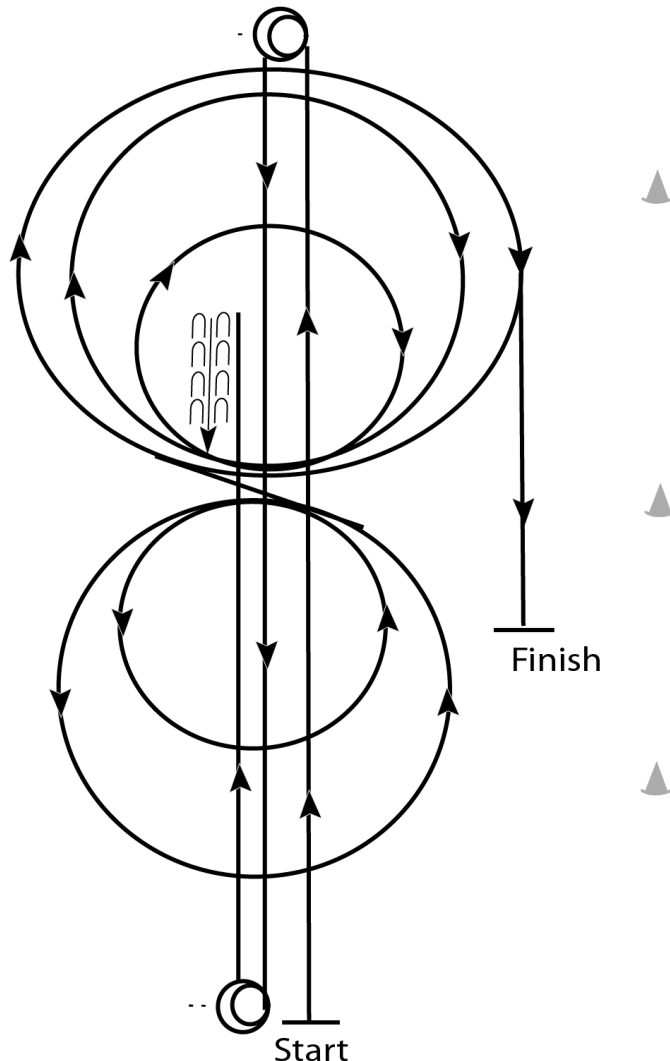

Pattern 4

1. Start at end of arena.
2. Run up center of arena past the end marker and come to a sliding stop. Complete 3 1/2 spins to the left.
3. Run to other end of arena past the end marker and stop. Complete 3 1/2 spins to the right.
4. Run past the center marker and stop.
5. Back at least 10 feet in a straight line.
6. Complete 1/4 turn to the left, hesitate. Beginning on the right lead, complete 2 circles to the right, the first one small and slow, and the second large and fast. Change leads at the center of the arena.
7. Complete one small, slow circle and one large, fast circle. Change leads to the right.
8. Run around end of arena to the other side, past center marker, at least 20 feet from fence and come to sliding stop.
9. Hesitate to complete pattern.

[NRCHAWC/4]

Pattern Provided by:

Judges

NQHA Hall of Fame Show

Level 1 Yth & Level 1 Am (Judges Arbo & Barry)

Show Date: Sunday, May 16th

REINING PATTERN B

Approved only for Level I Youth & Amateur, Youth I3 & Under

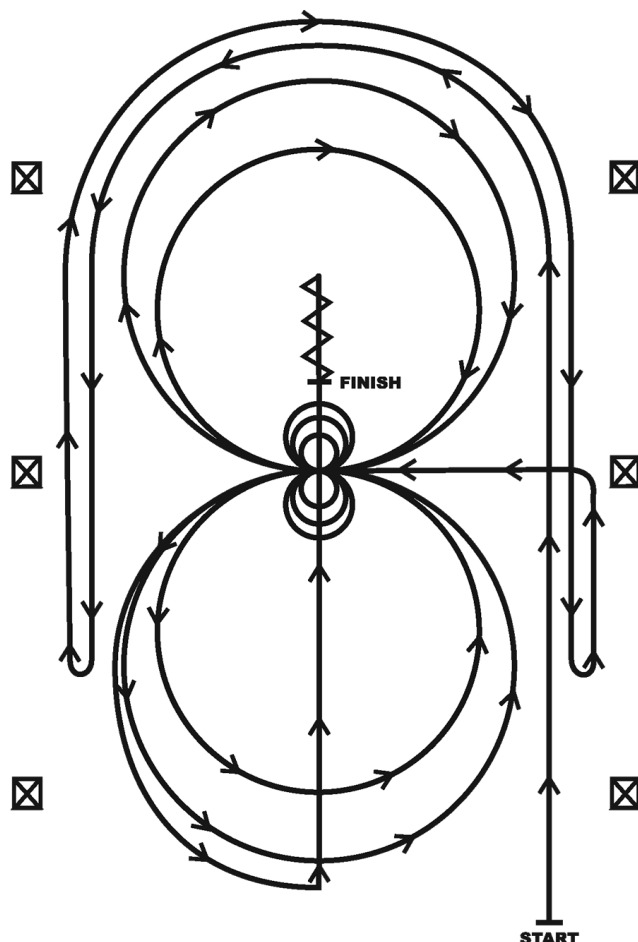

1. Beginning, lope straight up the right side of the arena, circle the top of the arena run straight down the opposite or left side of the arena past the center mark and do a right rollback—no hesitation.
2. Continue straight up the left side of the arena circle back around the top of the arena run straight down the right side of the arena past the center marker and do a left rollback—no hesitation.
3. Continue up the right side of the arena to the center marker, at the center marker the horse should be on the left lead and complete two circles to the left, one large fast and one small slow. Stop at center.
4. Complete three spins to the left. Hesitate.
5. Complete two circles to the right, one large fast and one small slow. Stop at center.
6. Complete three spins to the right. Hesitate.
7. Begin a large circle to the left, do not close the circle. Continue up the center of the arena past the center marker and do a sliding stop. 8. Back up at least ten feet. Hesitate to demonstrate completion of the pattern. See the Judges' Guide for a summary of other allowances made in the Handbook.

[R/AQHAP-B]

Pattern Provided by:

Judges

NQHA Hall of Fame Show

All Reining except Level 1 Yth & Lvl 1 Am (Judges Arbo & Barry)

Show Date: Sunday, May 16th

REINING PATTERN 7

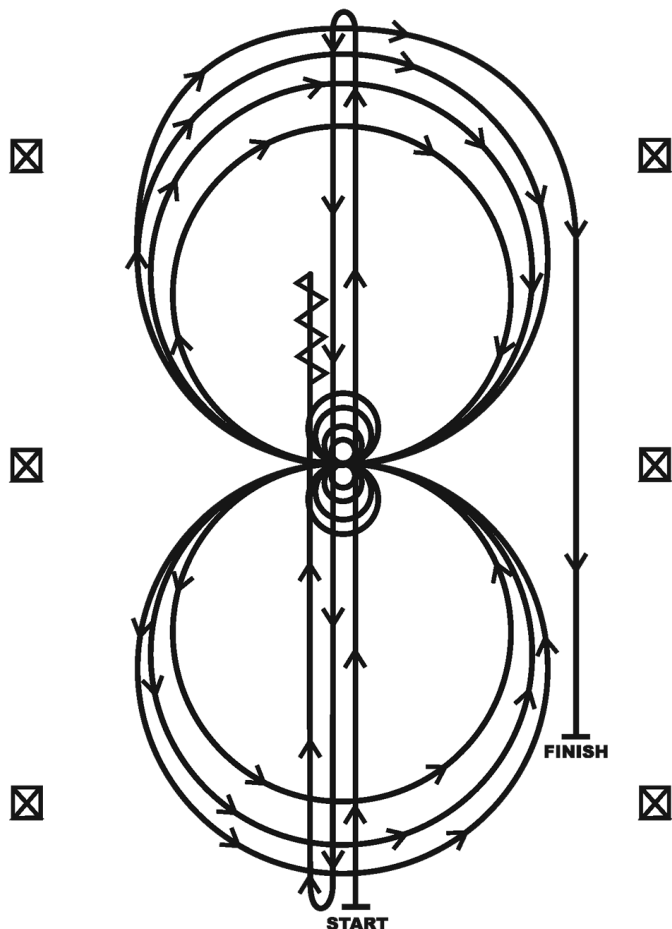

1. Run at speed to the far end of the arena past the end marker and do a left rollback—no hesitation.
2. Run to the opposite end of the arena past the end marker and do a right rollback—no hesitation.
3. Run past the center marker and do a sliding stop. Back up to the center of the arena or at least ten feet (three meters). Hesitate.
4. Complete four spins to the right. Hesitate.
5. Complete four and one-quarter spins to the left so that horse is facing left wall or fence. Hesitate.
6. Beginning on the right lead, complete three circles to the right: the first two circles large fast; the third circle small and slow. Change leads at the center of the arena.
7. Complete three circles to the left: the first two circles large fast; the third circle small and slow. Change leads at the center of the arena.
8. Begin a large circle to the right but do not close this circle. Run straight down the right side of the arena past the center marker and do a sliding stop at least twenty feet (six meters) from the wall or fence. Hesitate to demonstrate completion of the pattern.

[R/AQHAP-7]

Pattern Provided by:

Judges

